

**JUMBO-BV-VARIO-B / JUMBO-BV-VARIO-150-B /  
JUMBO-BV-VARIO-200-B / JUMBO-BV-VARIO-250-B**



GB | Operating Instructions

**Contents**

<b>1</b>	<b>EC-Declaration of Conformity / UKCA-Declaration of Conformity .....</b>	<b>4</b>
<b>2</b>	<b>Safety .....</b>	<b>6</b>
2.1	Safety Marking .....	6
2.2	Definition skilled worker / specialist.....	9
2.3	Personal safety requirements .....	9
2.4	Protective equipment.....	9
2.5	Accident prevention .....	9
2.6	Wheel loader safety.....	10
2.7	Safety in crane and travel operation .....	10
2.8	Safety during operation .....	10
2.8.1	General .....	10
2.9	Function Control .....	11
2.9.1	General .....	11
2.9.2	Electric .....	11
2.10	Suction plates .....	11
2.10.1	Avoiding damage .....	11
<b>3</b>	<b>General .....</b>	<b>12</b>
3.1	Authorized use .....	12
3.2	Survey and construction.....	14
3.3	Technical data .....	14
3.4	Definition working load limit.....	15
<b>4</b>	<b>Installation.....</b>	<b>16</b>
<b>5</b>	<b>Installation.....</b>	<b>16</b>
5.1	Mounting hollow prongs (optional) .....	16
5.2	Adjusting the forks.....	16
5.3	Mounting on wheel loader .....	17
5.4	Erect mast .....	18
5.5	Alignment of the mast transverse to the direction of travel g.....	20
5.6	Hook in lifting unit HE .....	21
5.7	Secure/unsecure lifting unit HE .....	22
<b>6</b>	<b>Operation.....</b>	<b>23</b>
6.1	General.....	23
6.2	Commissioning.....	23
6.1	Setting the floating state on the control unit .....	25
6.1.1	Set floating state without load .....	25
6.1.2	Set floating state with load .....	25
6.1.2	General information .....	26
6.2	Valve tappet adjustment.....	26
6.3	Setting the swivelling range .....	28

<b>7</b>	<b>Transport</b> .....	<b>31</b>
7.1	Secure articulated boom .....	31
7.2	Lowering the mast .....	31
7.3	Lifting the device .....	32
7.4	Dismantling articulated boom (maintenance work) .....	33
<b>8</b>	<b>Maintenance and care</b> .....	<b>34</b>
8.1	Maintenance .....	34
8.1.1	Suction plates/sealing lips.....	35
8.2	Troubleshooting.....	35
8.2.1	Mechanics .....	37
8.3	Repairs .....	38
8.4	Safety procedures .....	38
8.5	Hints to the type plate.....	39
8.6	Hints to the renting/leasing of PROBST devices .....	39
<b>9</b>	<b>Disposal / recycling of devices and machines</b> .....	<b>40</b>

*We hereby reserve the right to make changes to the information and illustrations in the operating instructions.*

## 1 EC-Declaration of Conformity / UKCA-Declaration of Conformity

Description: Vacuum Kerb Stone Installation Machine JUMBO-BV-VARIO  
 Type: JUMBO-BV-VARIO-B / JUMBO-BV-VARIO-150-B /  
 Order number: JUMBO-BV-VARIO-200-B / JUMBO-BV-VARIO-250-B  
 52200016 / 52200016-150 / 52200016-200 / 5220016-250

Manufacturer: Probst GmbH  
 Gottlieb-Daimler-Straße 6  
 71729 Erdmannhausen, Germany  
 info@probst-handling.de  
 www.probst-handling.com



Importer: Probst Ltd  
 Unit 2 Fletcher House  
 Stafford Park 17  
 Telford Shropshire TF3 3DG, United Kingdom  
 www.probst-handling.co.uk  
 sales@probst-handling.co.uk



The machine described above complies with the relevant requirements of the following EU directives:  
*The object of the declaration described above is in conformity with the relevant UK-Regulations and UK-Guidelines:*

**EC-machinery directive 2006/42/EC** (Reference: OJ L 157, 09.06.2006)

*UK-Regulation: Supply of Machinery (Safety) Regulations 2008 (SI 2008 No. 1597)*

The following standards and technical specifications were used:

### **DIN EN ISO 12100**

Safety of machinery - General principles for design - Risk assessment and risk reduction

*UK-Regulation: BS EN ISO 12100-1:2003+A1:2009*

### **DIN EN ISO 13857**

Safety of machinery - safety distances to prevent hazard zones being reached by upper and lower limbs.

*UK-Regulation: BS EN ISO 13857:2019*

**2014/30/EU (Electromagnetic compatibility)** / (Reference: OJ L 96, 29.03.2014)

*UK-Regulation: Electromagnetic Compatibility Regulations 2016 (SI 2016 No. 1091)*

### **DIN EN 60204-1 (IEC 60204-1)**

Safety of machinery, electrical equipment of industrial machines. Part 1: General requirements.

*UK-Regulation: BS EN 60204-1:2018*

### **DIN EN 1012-1 / DIN EN 1012-2**

Compressors and vacuum pumps; Safety requirements part 1 and 2.

*UK-Regulation: BS EN 1012-1:2010*



**Authorized person for EC-documentation:**

Name: Jean Holderied

Address: Probst GmbH; Gottlieb-Daimler-Straße 6; 71729 Erdmannhausen, Germany

**Authorized person for UK-documentation:**

Name: Nigel Hughes

Address: Probst Ltd ; Unit 2 Fletcher House; Stafford Park 17; Telford Shropshire TF3 3DG, United Kingdom

**Signature, information to the subscriber:**

Erdmannhausen, 23.02.2024.....



(Eric Wilhelm, Managing Director)

## 2 Safety

### 2.1 Safety Marking

#### PROHIBITION SIGN

Symbol	Meaning	Order-No.	Size
	It is not allowed to stand under hanging loads. <b>Danger to life!</b>	29040210 29040209 29040204	Ø 30 mm Ø 50 mm Ø 80 mm
	Do not lift any components off-centre.	29040383 29040594	102x52 mm 65x33 mm

#### WARNING SIGN

Symbol	Meaning	Order-No.	Size
	Danger of squeezing the hands.	29040221 29040220 29040107	30 x 30 mm 50 x 50 mm 80 x 80 mm
	Danger: Injury of hands and fingers – belt drive	29040451	48 x 54 mm
	Warning of electric voltage.	29040397	31 x 27 mm

#### REGULATORY SIGN

Symbol	Meaning	Order-No.	Size
	The specification of the maximum load limit (WLL) on the type plate of the suction plate has priority!	29040730	48 x 125 mm
	Each operator must have read and understood the operating instructions (and all safety instructions).	29040665 29040666 29041049	Ø 30 mm Ø 50 mm Ø 80 mm



Clean the filter insert daily with compressed air. Do not knock out the filter insert! Exchange if very dirty.

29040687

Ø 50 mm



Use ear protection

29040298

Ø 50 mm





Suspension point for transport belt/chain for lifting the machine/device (for following transport, loading, recovery).

29040370

23 x 60 mm

**OPERATING INFORMATIONS**

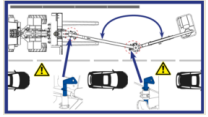
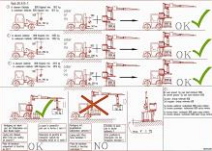
Symbol	Meaning	Order-No.	Size
	Functions of the operating valve and lifting unit	29040384	143x98 mm
	Adjustment of hovering state without load of operating valve and lifting unit.	29040385	30x80 mm
<b>250 kg</b>	Maximum working load limit (WLL) = 250 kg → with a boom length of 3500 mm. (with a correspondingly permissible lifting unit)	29040562	35x80 mm
	Limit the swivel range: Insert socket pin on the <b>left-hand</b> boom side to avoid swivelling to the <b>left</b> (into road traffic).	29041100	180x100 mm
	Limit the swivel range: Insert pins on the <b>right-hand</b> side of the boom to avoid swivelling to the <b>right</b> (into road traffic).	29041099	180x100 mm
	Even ground → 80% tipping load → minimum xx kg Uneven ground → 60% tipping load → minimum xx kg	29040339	275x195 mm

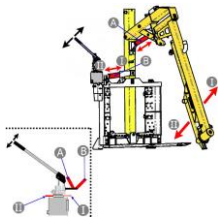

Operation of hand pump:

Red adjusting lever (Pos A)

- adjusting lever on pump I → mast alignment (right)
- adjusting lever on pump II → mast alignment (left)

29040476 137x135 mm

Red adjusting lever (Pos B)

- adjusting lever on pump I → raise crane jib
- adjusting lever on pump II → lowering crane jib

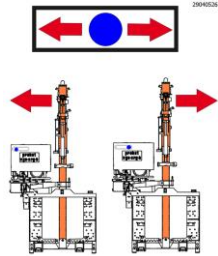

Mast adjustment left/right

29040526 90x80 mm

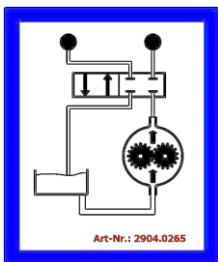

Connection hydraulics on the JUMBO-BV

29040265 65x80 mm

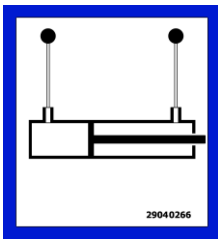

Cylinder connection on the JUMBO-BV

29040266 73x80 mm

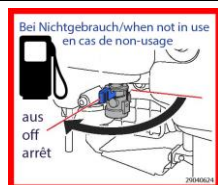

When not in use, close the fuel tap

29040624 58x50 mm

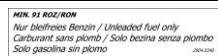

Only use unleaded petrol

29040340 30x130 mm

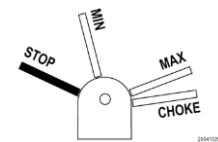

Speed positions/regulating levers (of the petrol engine)  
Stop, Minimum, Maximum, Choke

29041029 70x100 mm

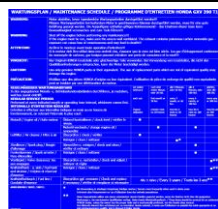

Maintenance for Honda engines (DE/ GB/ FR)

29040329  
29040330 195x190 mm  
29040331

## 2.2 Definition skilled worker / specialist

Only skilled workers or specialists are allowed to carry out the installation-, maintenance-, and repair work on this device!

Skilled workers or specialists must have for the following points (if it applies for this device), the necessary professional knowledge.

- for mechanic
- for hydraulics
- for pneumatics
- for electrics

## 2.3 Personal safety requirements



Each operator must have read and understood the operating instructions (and all safety instructions). Only qualified, authorized personal is allowed to operate the device and all devices which are connected (lifting device/carrier).



The **manual guiding** is **only** allowed for devices **with handles**. **Otherwise there is a risk of injury to the hands!**

## 2.4 Protective equipment

The protective equipment must consist, according to the safety regulations of the following parts:

- Protective clothing
- Safety gloves
- Safety shoes

## 2.5 Accident prevention



- The workplace has to be covered for unauthorized persons, especially children.
- **Caution at thunderstorm - danger of lightning!**  
Depending on the intensity of the thunderstorm, stop working with the device if necessary.



- The workplace must be sufficiently illuminated.
- **Be careful with wet, frozen, iced and dirty building materials! There is a danger of the gripping material slipping out. → DANGER OF ACCIDENT!**

## 2.6 Wheel loader safety



- The wheel loader **must be** sufficiently dimensioned (see chapter "Technical data") to be able to operate the JUMBO-BV-VARIO-B safely and without malfunctions.
- The wheel loader driver **must** meet the legally prescribed qualifications and have a valid driving license.



- The wheel loader used must be in safe operating condition and comply with the regulations of the Road Traffic Regulations.
- All valid safety regulations for wheel loaders must be observed.
- If the wheel loader is driven on public roads, the JUMBO-BV-VARIO-B unit must be registered in the wheel loader's operating license.



- **The maximum allowable load of the wheel loader must not be exceeded under any circumstances!**

## 2.7 Safety in crane and travel operation



- - The wheel loader may only be driven if:
  - the lifting hose unit HE is properly secured against swinging around,
  - the articulated (knuckle) boom is secured with a safety bolt against swinging around.
- Only switch on the vacuum blower when the operating lever of the operating valve unit BE-SPRINT-2 is fully set to "lower" and the JUMBO-BV-VARIO-B unit is not resting on the load (kerb), otherwise it may jump up when switched on.
- Never release the control lever while the load (kerbstone) is being lifted.
- Whenever work is interrupted, the load (kerbstone) must be put down and the vacuum blower switched off.
- **Never stop work with the load (kerbstone) lifted, as there is a risk of the gearbox from overheating.**
- In case of motor failure, immediately move the operating lever to "lift" so that the load (kerbstone) **does not fall**, and the rest vacuum ensures that the BE-SPRINT-2 operating unit slowly lowers.



- **Always** close the sound insulation bonnet of the blower unit.
- The wheel loader **must not be jacked up** on the forks of the device (JUMBO-BV-VARIO-B).
- The wheel loader **must not be driven** if a load (kerbstone) has already been sucked or is being sucked.

## 2.8 Safety during operation

### 2.8.1 General



- **This appliance may only be used at ground level!**  
**In hoist operation: The load must be lowered to just above the ground (approx. 0.5 m) immediately after being picked up (e.g. from a pallet or truck). The load must then be secured by the load securing chain and only then may it be transported to the installation point. Only lift the load as high as necessary for transportation (recommendation approx. 0.5 m above the ground). Do not swing the appliance over people. Danger to life!**



- Manual guidance is only permitted for devices with handles
- The operator must not leave the control position while the device is loaded and must always keep an eye on the load.
- The operator must always keep an eye on the pressure gauge to check whether a vacuum vacuum is present during the suction process. If no vacuum vacuum is displayed, **Set the load down immediately. Load will fall down → Risk of injury!**



- Persons are not permitted in the work area during operation! Unless it is absolutely necessary. Due to the way the appliance is used, e.g. by manually guiding the appliance (by handles).
- Standing under a suspended load is prohibited. **Danger to life!**
- Never pull or drag loads at an angle.
- Never suction the load off-center, otherwise there is a **risk of tipping**.
- Only remove the load from the suction plate when it is completely and securely on the floor or stationary. **Keep your fingers away from the load when releasing it. Risk of crushing!**



- Do not exceed the load-bearing capacity and nominal widths/nominal sizes of the device
- Do not use the device to pull off fixed loads.



- Jerky lifting or lowering of the appliance with or without a load is prohibited!
- Avoid unnecessary vibrations. The same applies to driving quickly with the carrier/lifting gear over uneven terrain!
- **Danger to life:** Load could fall down or load handling attachments could be damaged! In general, only drive at **walking speed** with the load lifted!

## 2.9 Function Control

### 2.9.1 General



- Before every usage of the device check the functions and the working condition.
- Maintenance and lubrication are only permitted when device is shut down!



- Do not use the device, until all faults which can cause safety hazards are removed.
- If there are any cracks, splits or damaged parts on any parts of the device, immediately stop using it.



- The operating instructions must be available at the workplace every time.
- Do not remove the type plate of the machine.
- Unrecognisable information signs (such as regulatory or prohibition signs) must be replaced.

### 2.9.2 Electric



- Check all electric cables for connection before each use.
- Defective electrical parts may be exchanged only by **qualified personnel** in the **dead condition**.
- The electric cables must be free of breaks and abrasion. Take care that there are no outstanding edges, where the hoses could get stuck.

## 2.10 Suction plates

### 2.10.1 Avoiding damage



- To avoid damage (cracks, material abrasion) to the rubber seal on the suction plate, the following must be noted:
- During operation of the device, it must generally be ensured that the suction plate does not touch or bump against other products or other objects when lifting, setting down or transporting products.
- Otherwise, the rubber seal may be damaged by the suction plate (risk of loss of suction power). The product (stone slab) could fall down. **Danger of accident!**

### 3 General

#### 3.1 Authorized use

The device (JUMBO-BV-VARIO-B) may only be used for lifting and moving kerbstones and dense stone slabs and the like and is suitable as an attachment to all wheel loader types (with fork carriage plate).



The use of the device (JUMBO-BV-VARIO-B) in closed rooms or explosion- and fire-endangered areas is prohibited due to the petrol engine (and the diesel engine of the wheel loader)!!

**There is a risk of poisoning/explosion and fire!**



- The device is only designed for the use specified in this documentation.
- Every other use is not authorized and is forbidden!
- All relevant safety regulations, corresponding legal regulations, especially regulations of the declaration of conformity, and additional local health and safety regulations must be observed.



Prior to every operation the user **must** ensure that:

- The equipment is suited to the intended operation
- the functioning and the working condition of the equipment is examined
- the load is suitable to be handled.

Any doubts about instructions should be raised with the manufacturer prior to use.





### NOT ALLOWED ACTIVITIES:

**Unauthorized alterations** of the device and the use of any self-made additional equipment could cause danger and are therefore **forbidden!**

Never exceed the **carrying capacity/working load limit (WLL)** and the **nominal width/nominal size** of the device.

### All unauthorized transportations with the device are not allowed:

- Transportation of people and animals.
- Transportation of other loads and materials than described in this manual.
- Never suspend any goods with ropes, chains or similar at the device.



**Only suction plates** of the manufacturer **PROBST** shall be used!!!



- Some suction plates which can be mounted to the device will reduce its working load limit.  
*The maximum working load limit is indicated on each suction plate.*
- Use only suction plates which are **approved** for this device!



**Do not exceed** the maximum working load limit of the suction plates!  
**Danger: Load (stone slabs) will fall down!**



**The use of suction plates with a smaller working load limit than the lifting unit is forbidden!**  
**DANGER: Load will fall down.** (It is permissible to use suction plates with a higher working load limit than the lifting unit)



**ATTENTION:** The use of this device is only permitted in proximity to the ground (→ chapter "Safety at work" and "Explanation of basic concepts").

- The load (stone slabs) which is to be sucked and transported, must have sufficient inherent stability, otherwise there is **risk of breakage** when lifting!
- Stone slabs **must not** be bend when lifting - especially take care with thin and large-sized stone slabs!
- Generally, the load (stones slab) is only to be sucked in the **middle**, otherwise the load hangs diagonally under the device which may cause a breaking of the load - especially when lifting large stone slabs with a small suction plate.
- Standard suction plates are not suitable for the transport of glass plates!

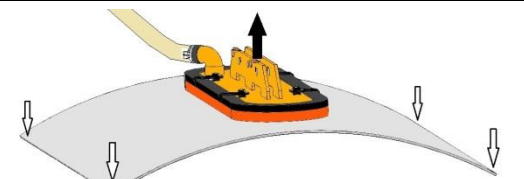
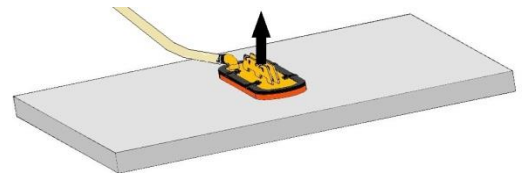

### 3.2 Survey and construction

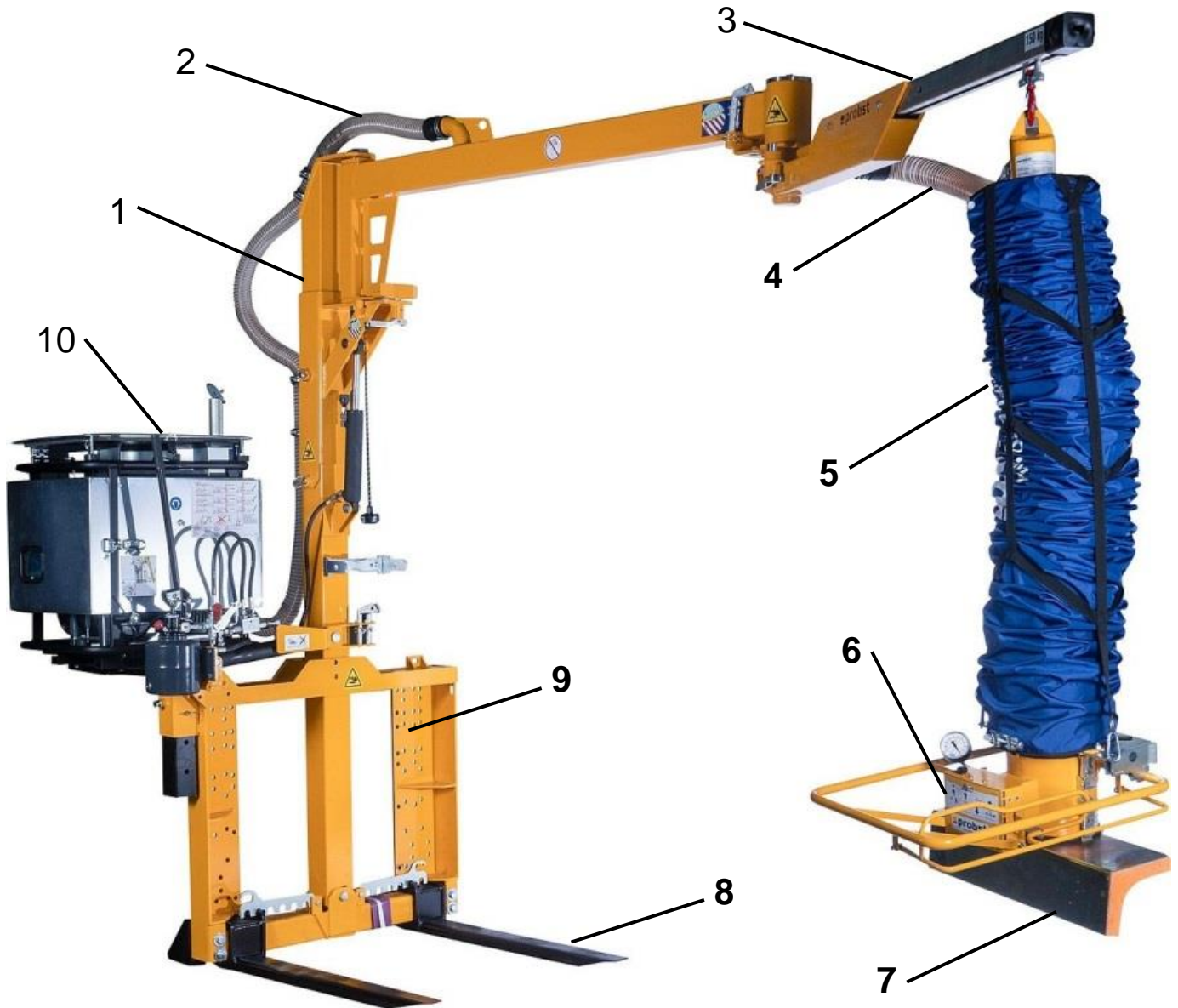

1	Mast	6	Operating valve unit BE-SPRINT-2
2	Vacuum supply hose	7	Angeled suction plate WSP
3	Articulated (knuckle) boom	8	Forks
4	Vacuum lifting hose	9	Mounting frame for wheel loader lifting plate
5	Lifting hose unit HE	10	Blower unit with petrol engine

### 3.3 Technical data

The exact technical data (carrying capacity / working load limit (WLL), dead weight, etc.) are listed on the type plate.

### 3.4 Definition working load limit

- ▶ Order-No.: 52200016-**150** = maximum Working Load Limit (WLL) **150 kg (331 lbs)** \* (with the lifting hose unit HE-150, this may be operated with a corresponding suction plate with a minimum Working Load Limit (WLL) of **150 kg** (331 lbs) or higher)
- ▶ Order-No.: 52200016-**200** = maximum Working Load Limit (WLL) **200 kg (441 lbs)** \* (with the lifting hose unit HE-200, this may be operated with a corresponding suction plate with a minimum Working Load Limit (WLL) of **200 kg** (441 lbs) or higher)
- ▶ Order-No.: 52200016-**250** = maximum Working Load Limit (WLL) **250 kg (551 lbs)** \* (with the lifting hose unit HE-250, this may be operated with a corresponding suction plate with a minimum Working Load Limit (WLL) of **250 kg** (551 lbs) or higher)

\* at low pressure – 420 mbar

**In general, the use of all Probst lifting hose units is allowed up to a working load limit (WLL) of 250 kg (551 lbs) with unrestricted load extension. The Working Load Limit (WLL) of the suction plate must always be the same or higher than that of the lifting hose unit!**

## 4 Installation

## 5 Installation

### 5.1 Mounting hollow prongs (optional)

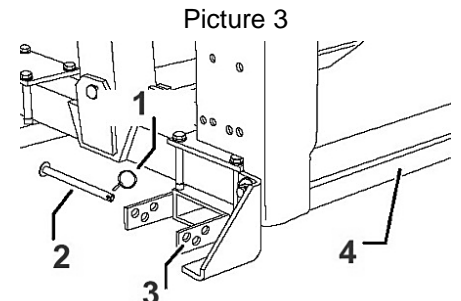
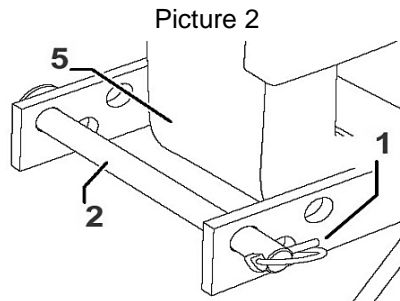
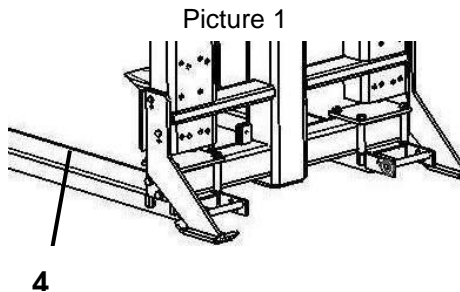

- The device can also be supplied with hollow tines (4) at the customer's request. This eliminates the need to attach the lifting plate to the wheel loader.
- Remove the linch pin (1) and locking pin (2) from the pin holder (3).
- Drive the forks (5) of the wheel loader fully into the hollow tines (4).
- Re-insert locking pin (2) and secure with linch pin (1) to prevent the fork tines (5) from slipping out of the hollow tines (4)



If the JUMBO-BV-VARIO with hollow forks is to be operated on a machine (wheel loader) to which the forks are not rigidly attached, suitable safety measures must be taken to **prevent** the forks from folding upwards or moving to the side. **Otherwise there is a high risk of accidents!**

### 5.2 Adjusting the forks

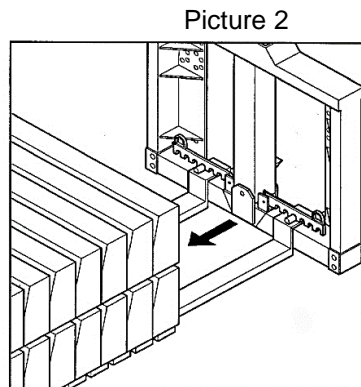
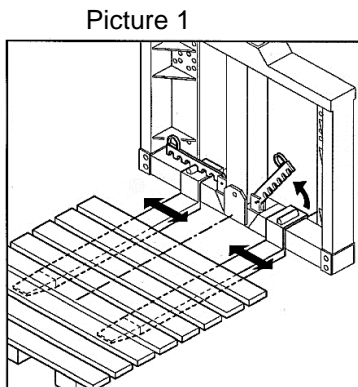

- Adjust the fork tines to the size of the pallet.
- Carefully drive the forks into the pallet.



The wheel loader must NOT be jacked up on the forks, otherwise they may break!

- Check all screws (see ↗ ) on hollow tines daily for tightness and retighten if necessary!

#### Hollow tines

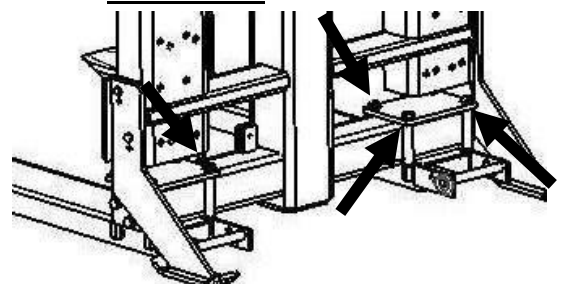



### 5.3 Mounting on wheel loader



The appliance (JUMBO-BV) must stand on horizontal and level ground. The jib arm must be in the lowered and folded position (transport position) Figure 1. The lifting and operating unit must NOT be on the articulated jib during assembly.

Picture 1



Picture 2



- Before fitting the brackets, first measure the height of the lift plate (e.g. 40 cm) and pre-assemble the upper brackets (see arrows).

Picture 3



- Measure the dimension from the centre of the hole to the contact edge on the claws (1.5 cm) and add this to the dimension of the lift plate height (here example:  $40+1.5+1.5 = 43$  cm)

Picture 4

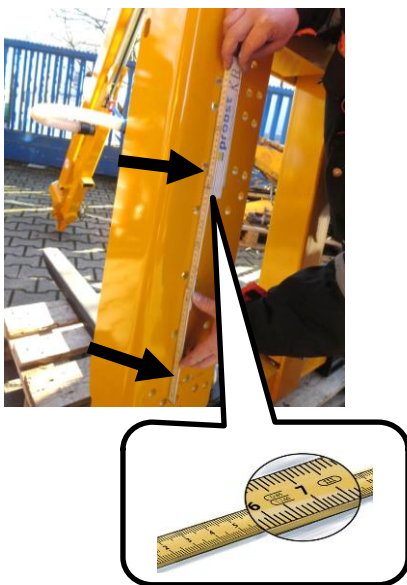

Picture 5

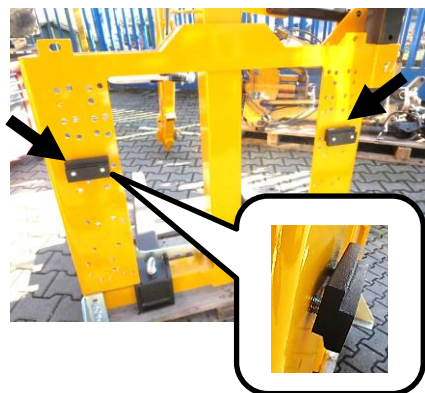
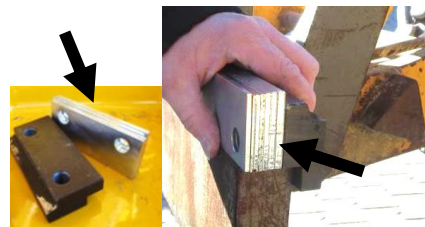

Figure 5A



Picture 6



- Find the determined dimension (43 cm) on the mounting frame using the corresponding hole spacing
- Position the wheel loader with lifting plate in the centre of the mounting frame on the JUMBO-BV lower bracket.
- The upper brackets on the lift plate must be pre-assembled first (see arrows). Do not tighten the screws completely yet.  
If necessary, use shims on the claws (Fig. 5A)
- Position the wheel loader with lifting plate in the centre of the mounting frame on the JUMBO-BV-VARIO and attach to the upper claws.

Picture 7

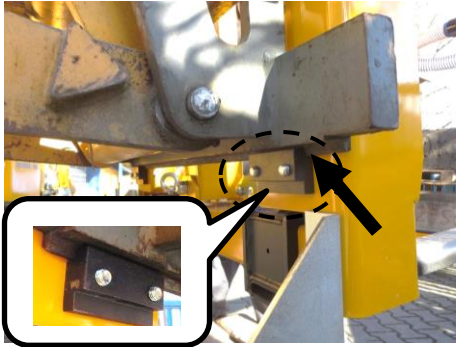

- Fit the lower brackets.

Picture 8



- First tighten all screws of the upper brackets.

Picture 9

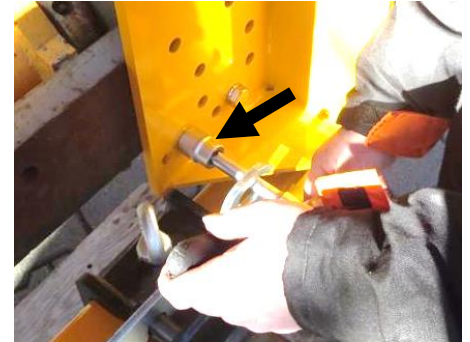

- Tighten all screws on the lower brackets.



**Check screw connections after 25 operating hours and retighten with the appropriate tools if necessary!**

#### 5.4 Erect mast



**The mast may only be erected when the device (JUMBO BV VARIO) is mounted on the wheel loader and the forks are on safe ground! Otherwise there is a risk of tipping and accidents!**



**Persons are prohibited from standing in the swivelling area while the mast/jib is being raised!  
→ Risk of injury!**

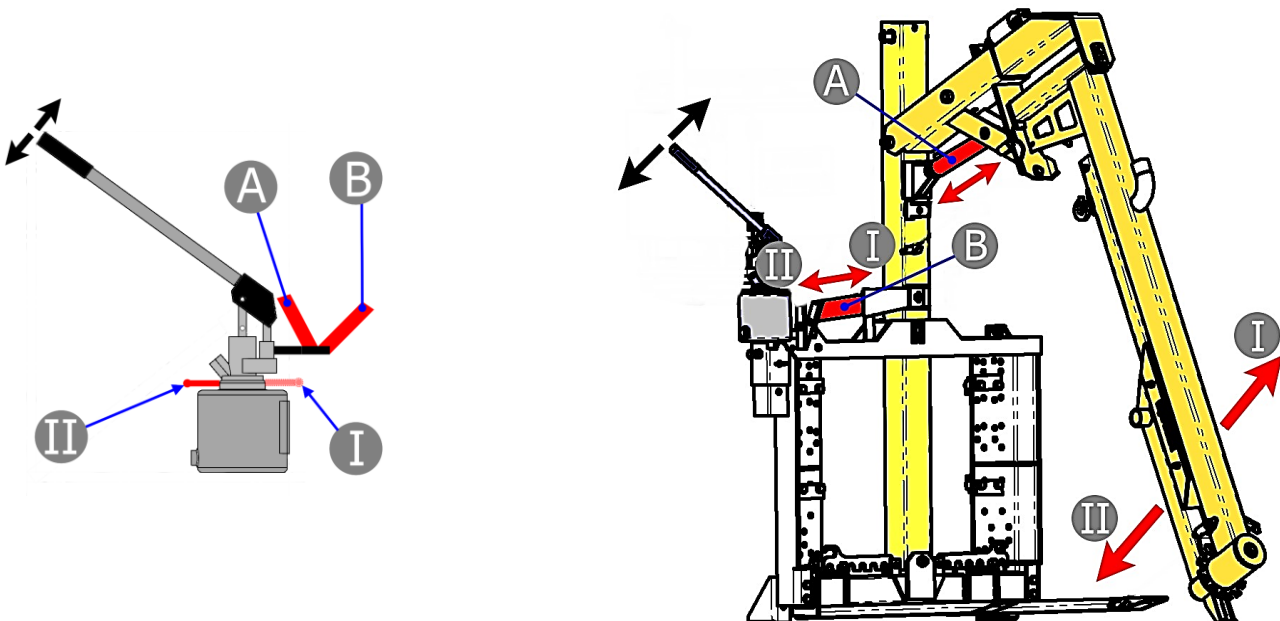



Move the red setting lever to position A



Move the adjusting lever on the hand pump to position I



Actuating the hand pump raises the mast.

As soon as the mast has reached the end position, it must be fixed in the upper insertion position (↘) with ring bolts and linch pins.

The mast is aligned in the direction of travel using the lifting plate of the carrier.

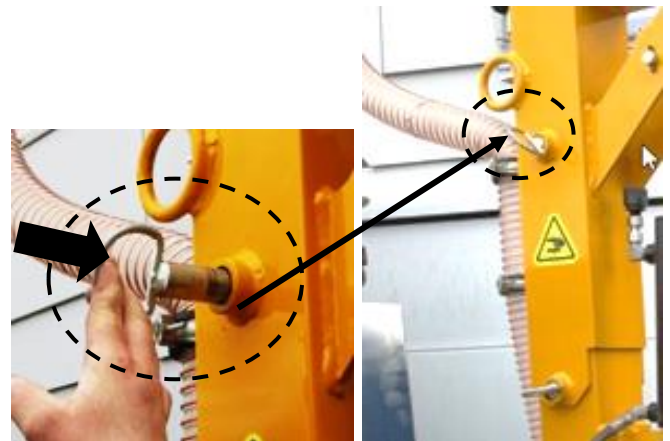



5.5 Alignment of the mast transverse to the direction of travel g

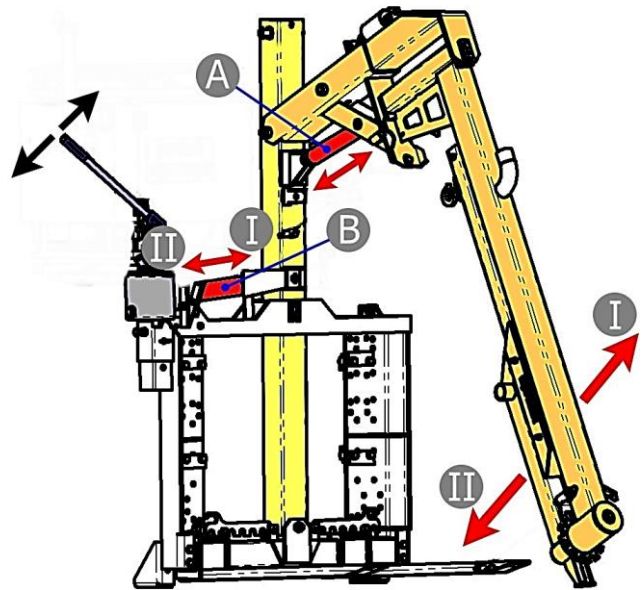
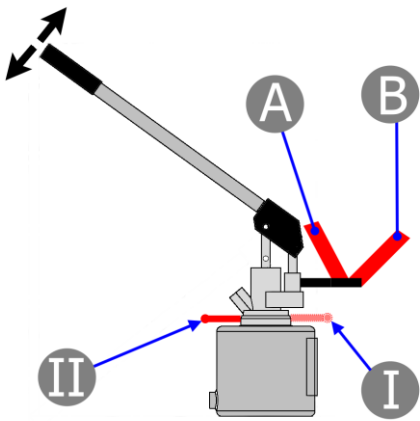

Move the red setting lever to position B



Move the adjusting lever on the hand pump to position I



Actuating the hand pump moves the mast to the right.



Move the red setting lever to position B

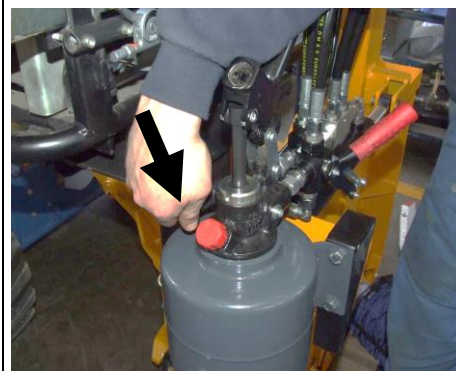

Move the adjusting lever on the hand pump to position II



Actuating the hand pump moves the mast to the left.



- The mast is optimally aligned as soon as the plumb line is in the correct position (both tips of the plumb line indicator must point towards each other).

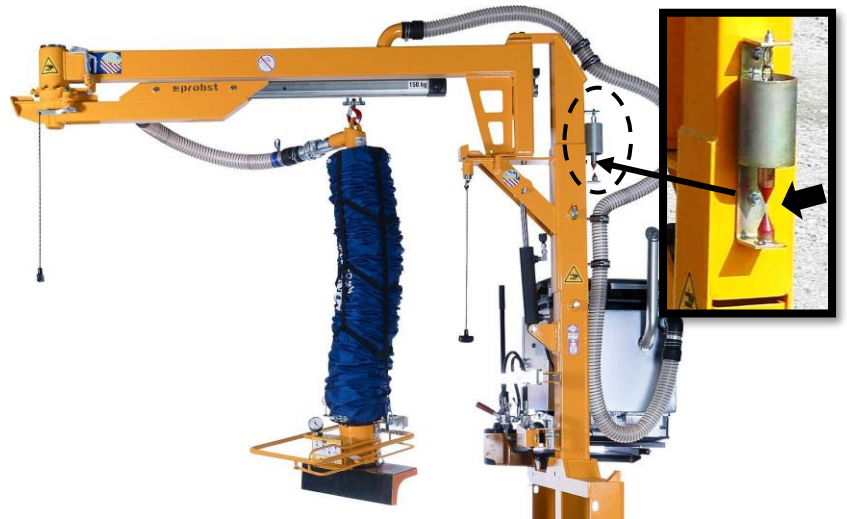

### 5.6 Hook in lifting unit HE

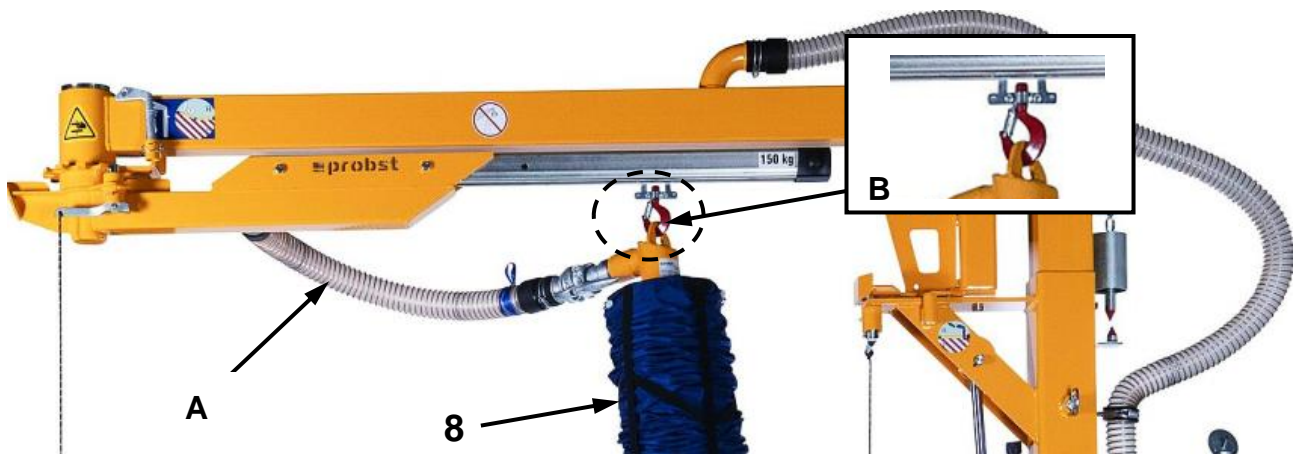

- Attach the lifting unit (8) to the travelling carriage (B) on the extension arm.
- Connect the vacuum supply hose (A) to the lifting unit (8) and secure with a clamp.

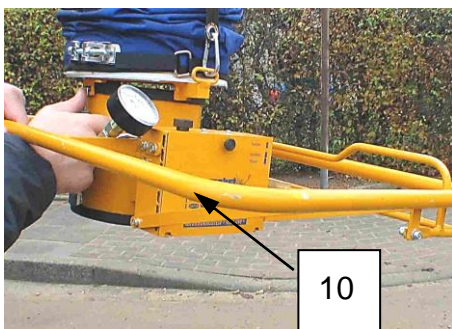

- Connect the operating unit to the lifting unit.

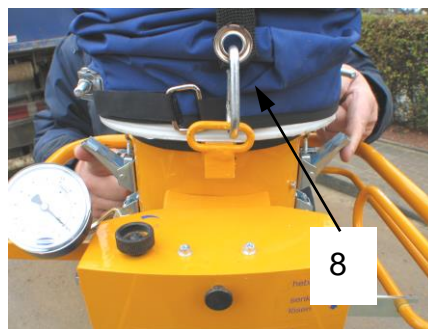

- Connect the lifting unit (8) to the control unit (10) and secure with clamps.

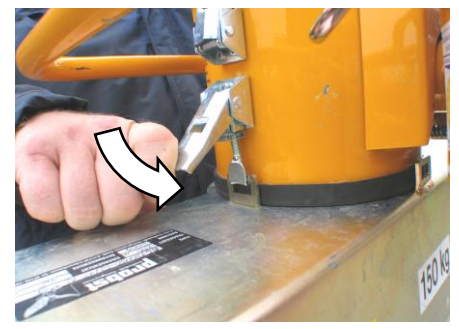

- Secure the control unit (10) and suction plate with clamps. **Ensure that the hooks are correctly attached!**

### 5.7 Secure/unsecure lifting unit HE



The lifting unit/operating unit must be secured against swivelling by the suspension device during all movements of the wheel loader.

Engage both spring latches so that the lifting unit cannot come loose from the suspension device (park position).

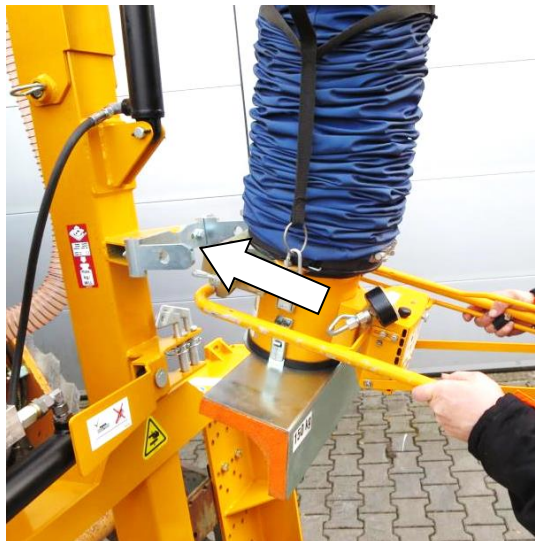

Fig. A1



Fig. A2

## 6 Operation

### 6.1 General



If the device is NOT mounted on a wheel loader, lifting a load (kerb) with the vacuum lifting unit is prohibited! There is a risk of tipping and accidents (see Fig. B)!



Picture A

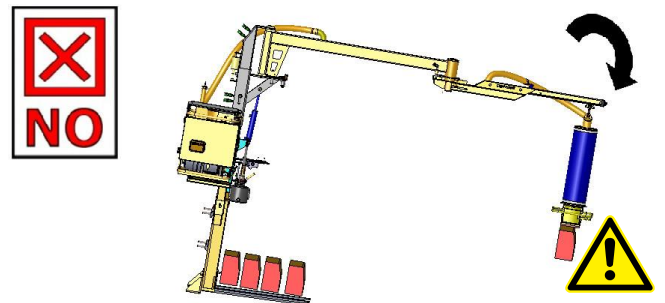

Picture B

### 6.2 Commissioning

Fig. 3



- Open the petrol tap (↗).  
(See also the enclosed HONDA GXV 340 operating instructions)

Fig.4

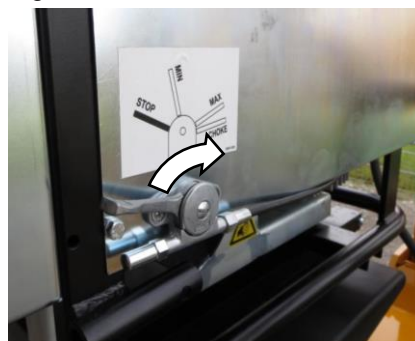

- Move the start/stop control lever all the way to the right to the yoke position.

Fig.5

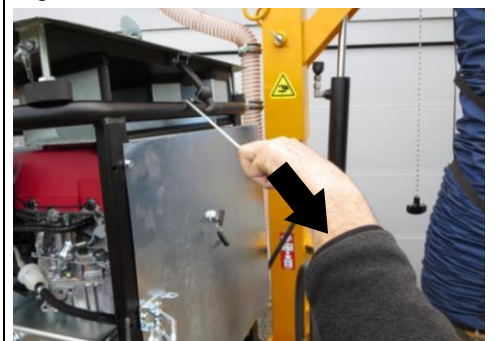

- Start the petrol engine by pulling the reserve start handle firmly. (VERSION I)

Fig.6



- Alternative: Starting via the electric starter (VERSION II)

Fig.7

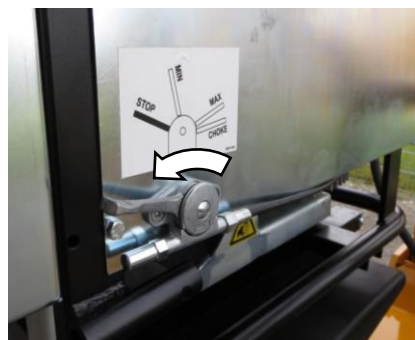

- Move the start/stop operating lever back slightly.

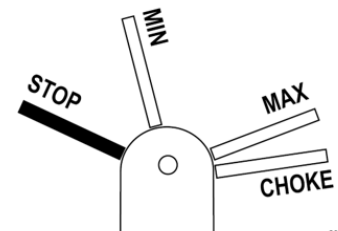

29041029





Before the carabiners of the retaining corset are opened, the **vacuum blower must ALWAYS** be in operation first, otherwise the lifting and operating unit will fall **down abruptly**→ **DANGER OF ACCIDENT!**

For the upcoming vacuum lifting operation, switch on the vacuum blower, then remove the lifting and operating unit from the suspension device (park position) (Fig. B1) by unlocking the spring cotter pins (Fig. A2).



Hold the lifting and operating unit firmly with both hands, as it can come loose from the suspension device (parking position) with a swing→ **Risk of injury/accident!**

Then pull the operating lever (↗) on the BE control unit upwards to "Suck in load" (so that the lifting unit comes up slightly) and only then open the two carabiners of the vacuum corset (Fig. A2) and attach them to the top of the corset (Fig. A3).



Fig.



Fig. A2

A1



Fig. B1



Fig. X



Fig. X1

## 6.1 Setting the floating state on the control unit

### 6.1.1 Set floating state without load



The floating state without load must be set before commissioning!

The hovering state of the lifting device must be adjusted to the respective gripper weight. A flap in the control unit is used for this purpose.

The position of the flap (2) can be changed.

When you place the suction pad on the load, the flap is fully opened via the plunger. This allows the load to be sucked in and lifted.

Procedure:

Turn the adjusting screw (1) on the control unit (accessible from below).

Turn clockwise → The flap is opened further.

Turn anti-clockwise → The flap is closed.

The wider the flap is open, the lower the appliance floats.



**If the flap is fully closed, the appliance will suddenly shoot up as soon as the fan is switched on!**

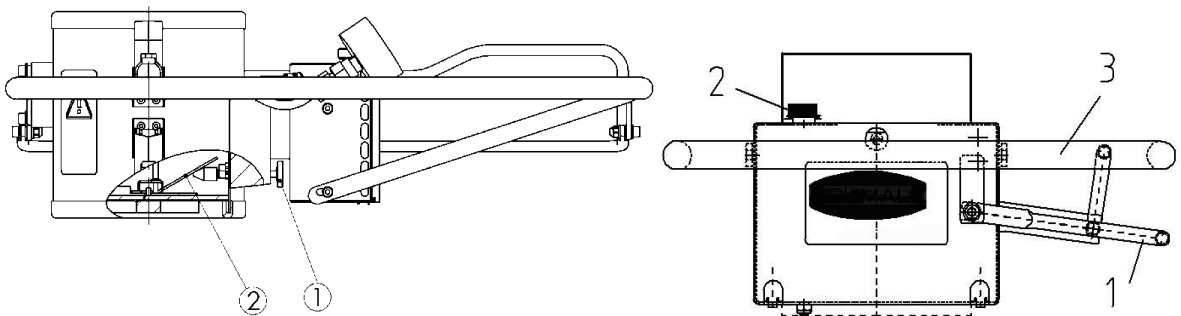

- Position the control unit in the centre above the load/curb and press the control lever (1) down. The lifting unit relaxes and the control unit lowers.
- Place the control unit in the centre of the load/curb.
- Slowly push the control lever on the operating unit upwards. The load is sucked in and the lifting unit contracts.



**The operating lever must not be left in the "suction/lifting" position for more than 90 seconds, as otherwise the fan may be damaged and fail (warranty void!) and energy is consumed unnecessarily.**

### 5.2.2 Setting the floating state with load

Adjust the adjusting screw (2) to set the hovering state with load (caution, not to be confused with the hovering state without load).

- ⇒ Clockwise rotation
  - Floating state is reduced
- ⇒ Twisting anti-clockwise
  - Floating state increases

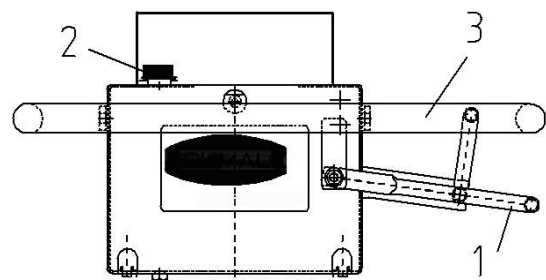



The operating lever must not be left in the "suction/lifting" position for more than 90 seconds, as otherwise the fan may be damaged and fail (warranty void!) and energy is consumed unnecessarily.

Suspended state **with load** should **NOT** be in the **highest lifting unit position**, as otherwise the fan may be **damaged** and fail when the load is sucked in (warranty claim becomes void!) and energy is consumed unnecessarily.

- **Carefully** transport the load/curb to its destination and set it down in the desired position by **slowly** pressing the control lever (1) downwards. The lifting unit is released and the operating unit lowers with the load.
- **DO NOT** press the control lever down abruptly as far as it will go while holding the operating handle (3). Otherwise the load may drop suddenly as the vacuum is completely released.
- Set down the load (kerb), tilt the operating unit slightly and remove it from the load/curb.

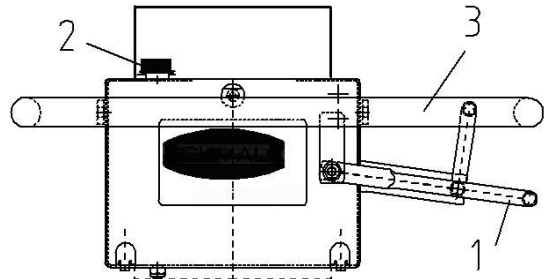

For further details, see the enclosed operating instructions for the BE-SPRINT-2 control unit/ HE lifting unit.

### 6.1.2 General information

Picture 15

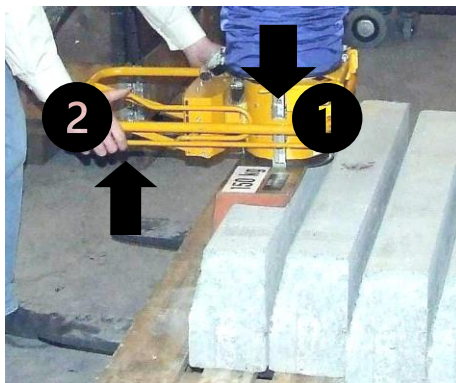

Picture 16

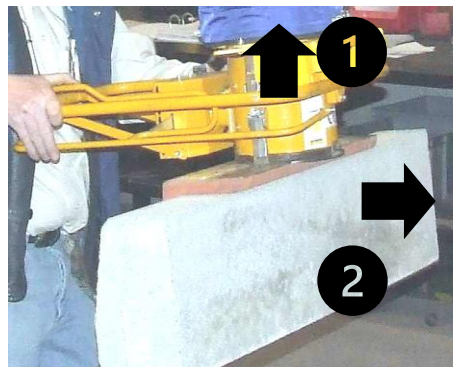

Picture 17

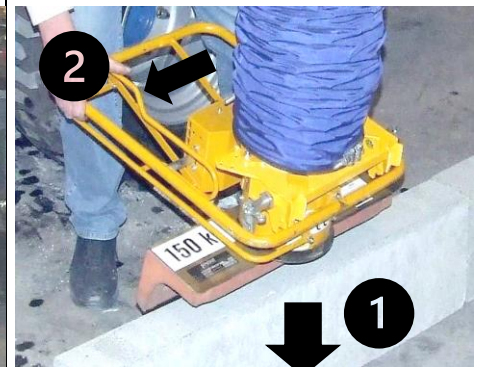

### 6.2 Valve tappet adjustment



The valve tappet (1) on the upper side of the suction plate (mounting side of the control unit) is set to 17 mm at the factory and secured with a lock nut.

**This distance "A"** (17 mm from the top edge of the screw to the connection ring) **must not be changed under any circumstances, otherwise the valve flap of the control unit will not switch correctly.**

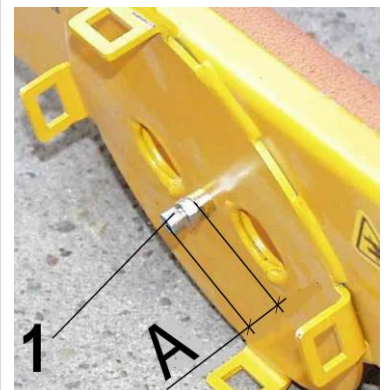



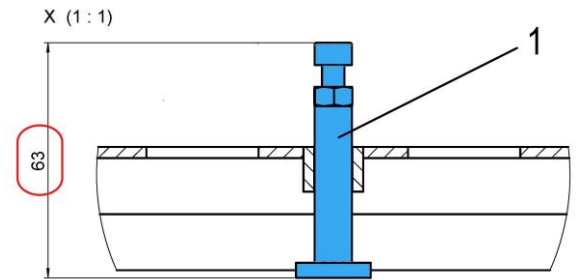
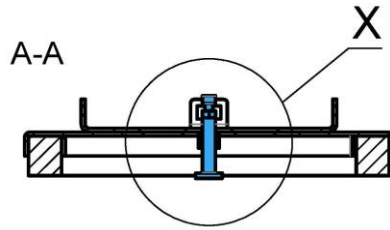
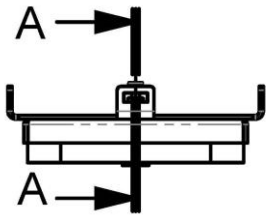

When using a hose cylinder extension SZV, the height dimension "L" on the SZV must match the setting dimension "l" of the ram ( ) on the SZV (303 mm). →

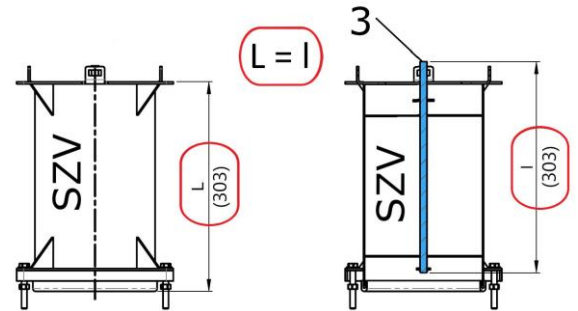

Due to the built-in valve tappet (1), the valve flap (2) on the control unit, which is used to set the floating state without load, is completely opened when the suction plate is placed on a load.

This makes suction much easier. In addition, a considerable gain in safety is achieved when lifting porous materials.

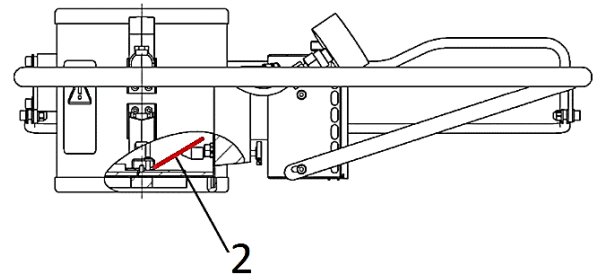

If the valve tappet often gets blocked on kerbs / slabs etc., it is also possible to work without the valve tappet in **exceptional cases** (dismantle).

The prerequisite for this is airtight materials. However, this must be tested by the user in each individual case.



- In case of motor failure the load does not drop (non-return valve)
- Residual vacuum slowly lowers the operating unit/lifting unit with the suctioned load.
- Adjust the motor speed so that there is a minimum vacuum of 0.42 bar (see pressure gauge ↘ on the control unit).



**Do not tear loose loads that are stuck!**  
**Do not interrupt work (breaks) with the load sucked in, danger of overheating of the vacuum blower!**



### 6.3 Setting the swivelling range



Depending on the situation in which the device is used, the swivelling range of the articulated boom may have to be limited ("SAFESTOP"). Kerbs are often laid on one side of the road while vehicles are allowed to drive on the opposite carriageway.

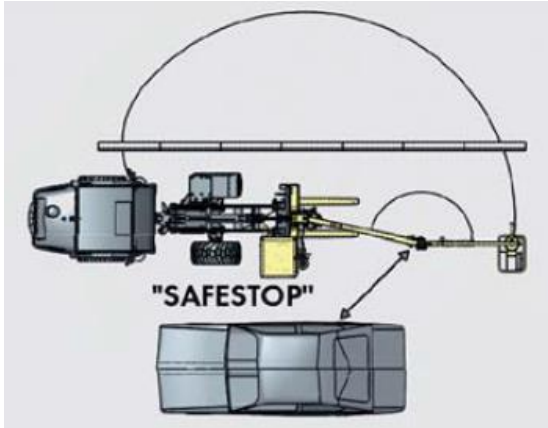

- Pull the cord (↙) to release the locking lever on the sprocket (bracket).

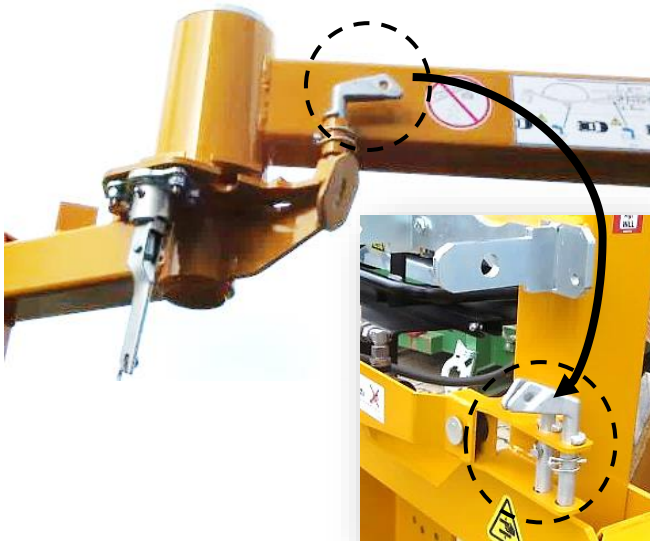

- Remove both socket pins on the boom (↗) to swivel the boom through 360°. Insert the socket pins into the slots provided on the mast for storage.

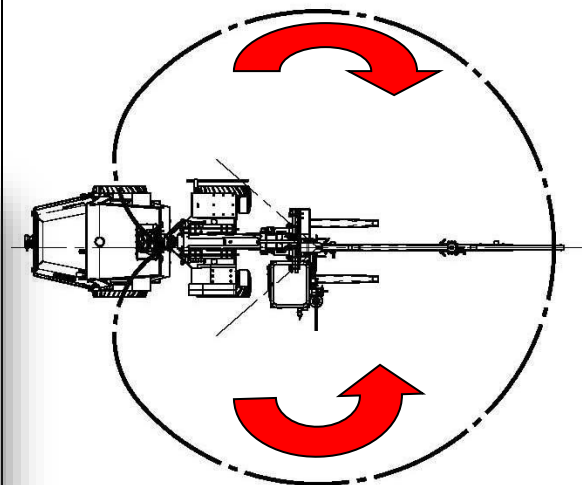

- The working range of the boom is approximately 360°.





A working range of 360° is not permitted when working directly on roads - risk of accidents with vehicles due to the vacuum lifting unit swinging out into the carriageway area.



For this purpose, the swivelling range of the jib arm must be limited for the endangered area (road with traffic) by means of pins on the jib arm!

- To limit the working range on one side (right in the direction of travel) (↙), the 2 pins on the right-hand side of the boom must be inserted.

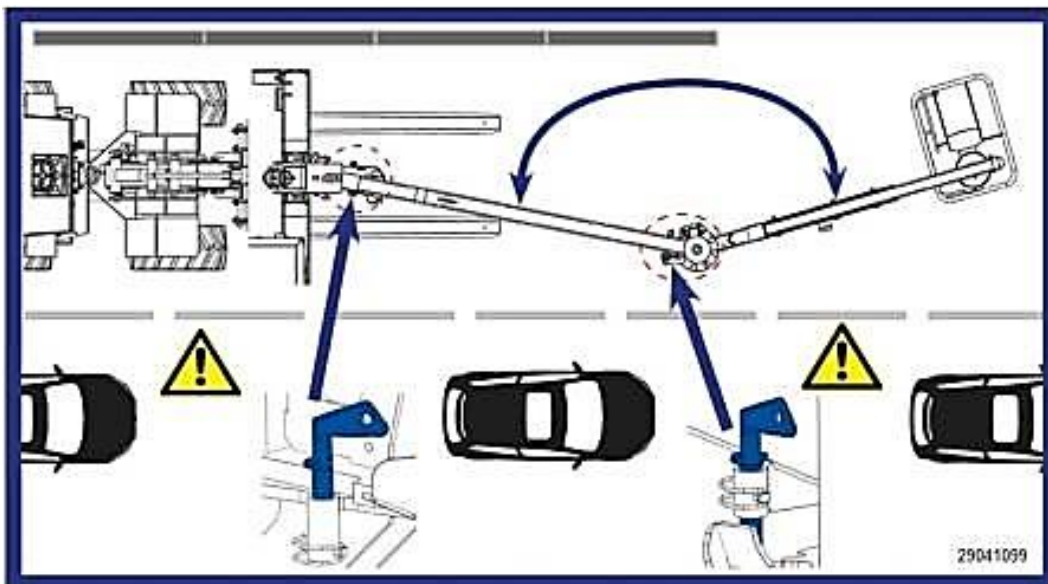
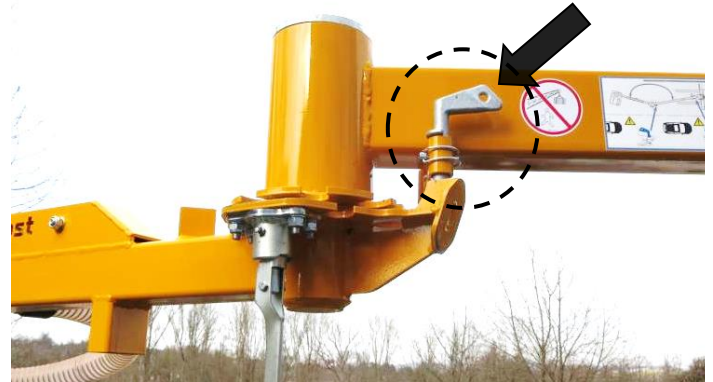

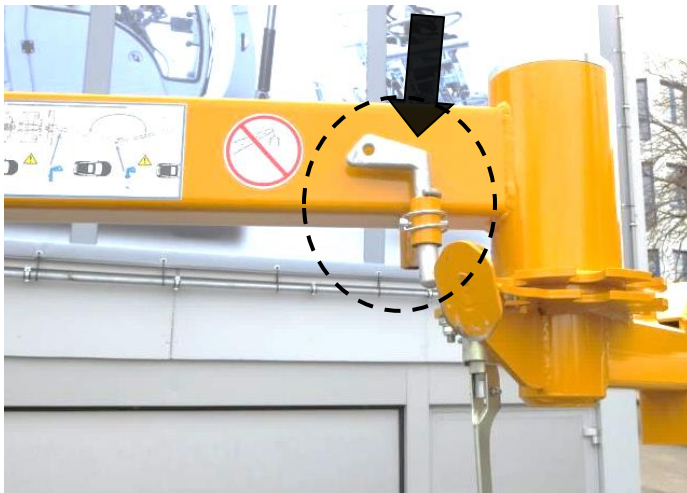

- To limit the working area on one side (left in the direction of travel) (↙), the 2 pins on the left-hand side of the boom must be inserted.

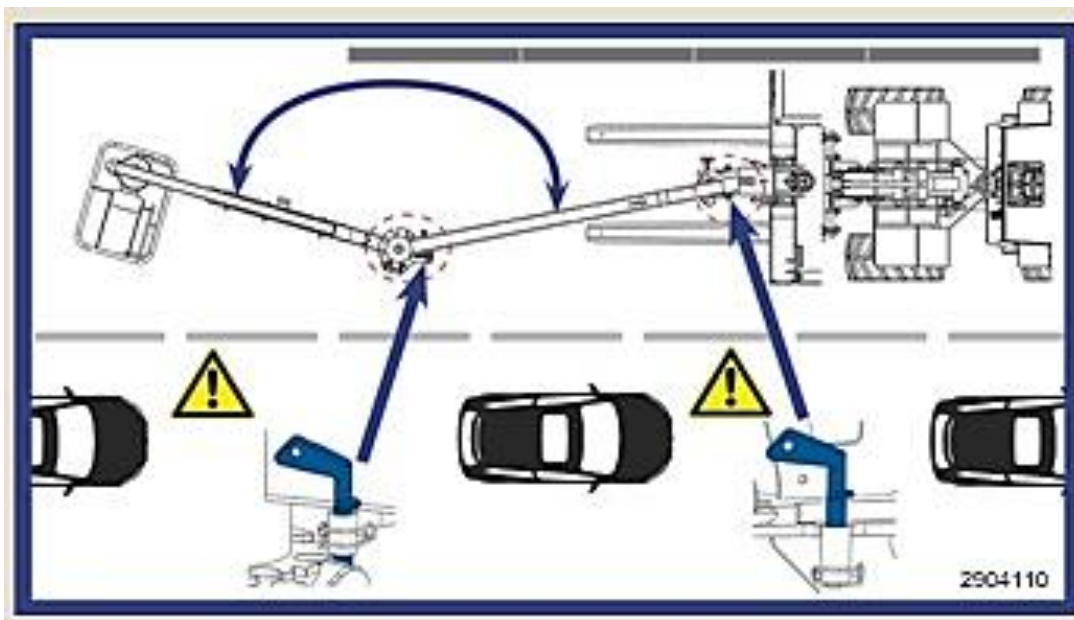

## 7 Transport



The appliance can be transported on a trailer, among other things - provided the dimensions and the authorised total weight are observed.

### 7.1 Secure articulated boom



- Transporting the device (e.g. on a trailer) **without a secured articulated boom** is expressly prohibited. Risk of accident due to swinging around!



- To do this, it is essential to bring the articulated boom into a rigid position by moving the two locking levers (at the two pivot points at the rear and in the centre) into a horizontal position.
- The lifting and operating unit (8) must be removed from the articulated boom!

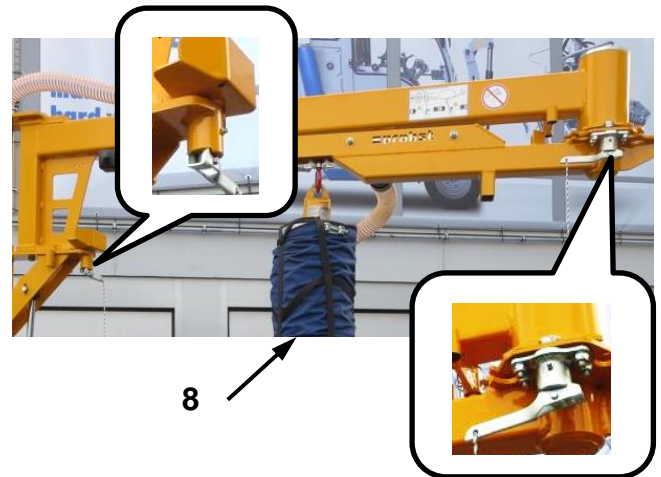

### 7.2 Lowering the mast



The mast may only be lowered when the implement (JUMBO BV VARIO-B) is mounted on the wheel loader and the forks are on safe ground!



It is forbidden for persons to remain in the swivelling area while the mast/jib is being lowered!  
→ RISK OF INJURY!

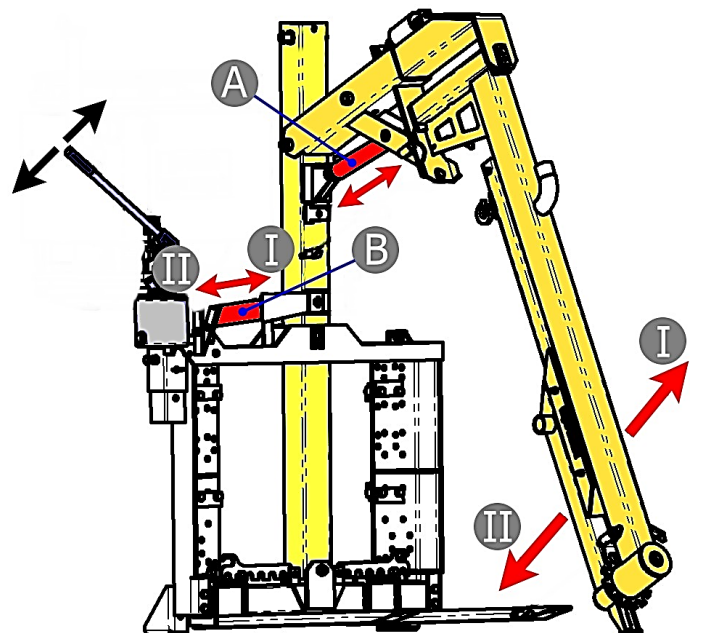
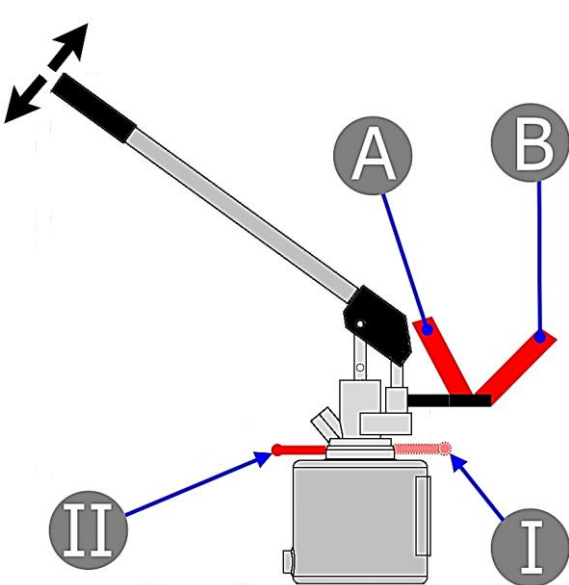



Move the red setting lever to **position A**

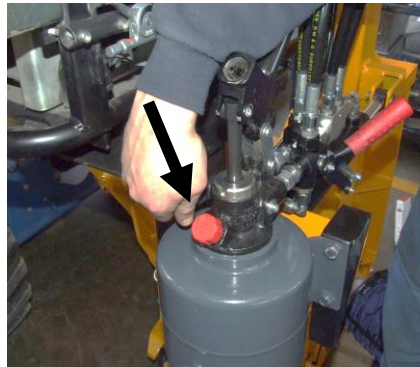

Move the setting lever on the hand pump to **position II**



Actuating the hand pump **lowers** the mast.

### 7.3 Lifting the device



Before the appliance (JUMBO BV VARIO-B) can be lifted, for example onto the loading area of a trailer, it must be disconnected from the lifting plate of the wheel loader.

First remove the lower brackets from the mounting frame and then the upper brackets (see also chapter "Mounting on wheel loader")

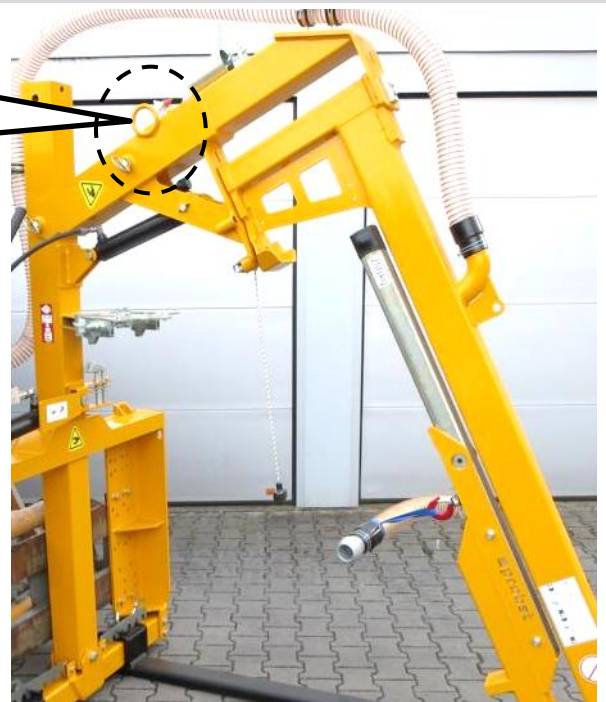

- The appliance (JUMBO-BV-VARIO) may **only** be lifted and transported using the two **lifting eyes** provided on the articulated jib!



- **Only sufficiently dimensioned lifting gear** (such as belts, chains, transport hooks) that are capable of safely bearing the weight of the appliance (JUMBO-BV-VARIO) may be used!



## 7.4 Dismantling articulated boom (maintenance work)



The suspension lug located in the centre of the boom is **ONLY** suitable for lifting and transporting the articulated boom removed from the mast, e.g. for maintenance work, using suitable lifting gear.



**Under no circumstances** may this suspension bracket be used to lift the **entire appliance** (JUMBO-BV-VARIO).

There is a **risk of damage** to parts of the appliance. → **RISK OF ACCIDENT** due to falling parts during the lifting process!

As the load capacity (WLL) of this suspension eye is **NOT** designed for the weight of the complete appliance.

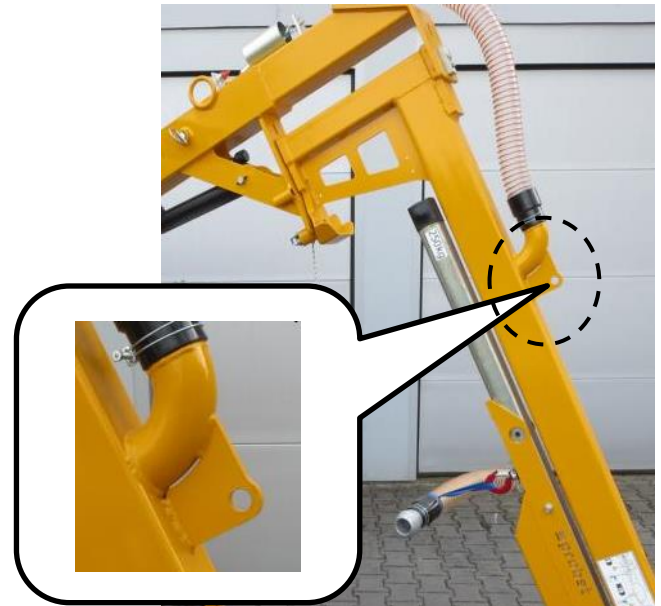

## 8 Maintenance and care

### 8.1 Maintenance



To ensure the correct function, safety and service life of the device the following points must be executed in the maintenance interval.

Used **only original spare parts**, otherwise the warranty expires.



All operations may only be made in closed state of the device!  
For all operations you have to make sure, that the device will not close unintended. **Danger of injury!**



To ensure proper function, operational safety and service life of the appliance, the maintenance work listed in the table must be carried out at the end of the specified intervals



All work may only be carried out with the appliance switched off!

Maintenance period	Work to be carried out
<b>Initial inspection after 25 operating hours</b>	<ul style="list-style-type: none"> <li>• Check or retighten all fastening screws (may only be carried out by an expert).</li> </ul>
<b>daily</b>	<ul style="list-style-type: none"> <li>• Check engine oil level (see Honda Owner's Manual)</li> <li>• Clean the air filter and fan (see Fig. 1-3)</li> </ul>
<b>weekly</b>	<ul style="list-style-type: none"> <li>• Check all fastening screws for tightness, tighten if necessary</li> <li>• Check the hydraulic system for leaks.</li> </ul>
<b>Monthly (every 50 operating hours)</b>	<ul style="list-style-type: none"> <li>• Tighten all fastening screws (ensure that the screws are tightened in accordance with the applicable tightening torques for the corresponding strength classes).</li> <li>• Check all existing safety elements (such as hinged cotter pins) for proper function and replace defective safety elements.</li> <li>• Check all joints, guides, bolts and sprockets, chains for proper function, adjust or replace if necessary.</li> <li>• All existing sliding guides, gear racks, joints of moving parts or machine components must be greased/lubricated to reduce wear and optimise movement sequences (recommended grease: <i>Mobilgrease HXP 462</i>).</li> <li>• Lubricate all grease nipples (if present) with a grease gun.</li> <li>• Change the engine oil according to the manufacturer's instructions (HONDA) (observe specification).</li> </ul>
<b>At least once a year</b> (shorten the interval under harsh operating conditions)	<ul style="list-style-type: none"> <li>• Checking the suspension parts, bolts and lugs</li> <li>• Inspection for cracks, wear, corrosion and functional safety by an expert (→ DGUV Rule 100-500).</li> </ul>

Picture 1



- Remove the filter cover (↙).

Picture 2



- Check the seal and replace if damaged.

Picture 3

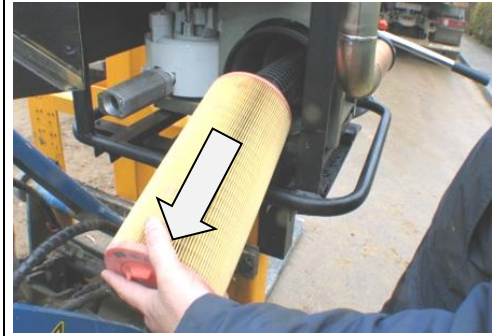

- Remove and clean filter (compressed air), replace if necessary

### 8.1.1 Suction plates/sealing lips

Clean the sealing lips at least once a week to remove adhering objects and dirt such as sand, stone particles, dust, etc. Clean sponge rubber with compressed air and/or water jet.

Wipe out the groove in the sealing lip with a cloth and/or blow out with compressed air.

Replace damaged or worn suction plates/sealing lips (cracks, holes, corrugation) immediately.

Use a cold cleaner to clean the appliance (do not use petrol or corrosive liquids. This would cause the hoses to leak or be destroyed).

### 8.2 Troubleshooting

Malfunction	Cause	Remedy
The mast cannot be aligned	<ul style="list-style-type: none"> <li>• The hydraulic system is leaking.</li> <li>• The hydraulic cylinders do not hold the pressure.</li> <li>• The valve has a malfunction.</li> </ul>	<ul style="list-style-type: none"> <li>• Tighten connections and screw joints.</li> <li>• Replace the gasket sets in the cylinders.</li> <li>• Check and clean the valve, replace if necessary.</li> </ul>
Jumbo-BV cannot be attached to wheel loader	<ul style="list-style-type: none"> <li>• False claws in use</li> </ul>	<ul style="list-style-type: none"> <li>• Use the right claws</li> </ul>
Stone pallets cannot be picked up	<ul style="list-style-type: none"> <li>• The fork spacing is set incorrectly</li> </ul>	<ul style="list-style-type: none"> <li>• Correctly adjust the fork spacing</li> </ul>
Boom swivels in the wrong direction	<ul style="list-style-type: none"> <li>• Swivelling range set incorrectly</li> </ul>	<ul style="list-style-type: none"> <li>• Set the swivelling range correctly</li> </ul>
Negative pressure of -0.42 bar not reached	<ul style="list-style-type: none"> <li>• Workpiece has cracks, recesses or is porous</li> </ul>	<ul style="list-style-type: none"> <li>• Workpiece not suitable for suction with this device</li> </ul>
	<ul style="list-style-type: none"> <li>• Suction plate seal is damaged</li> </ul>	<ul style="list-style-type: none"> <li>• Replace seal</li> </ul>
	<ul style="list-style-type: none"> <li>• Pressure gauge is defective</li> </ul>	<ul style="list-style-type: none"> <li>• Replace pressure gauge</li> </ul>
	<ul style="list-style-type: none"> <li>• Hose, screw connections leaking</li> </ul>	<ul style="list-style-type: none"> <li>• Replace components</li> </ul>
No vacuum available/ device does not work	<ul style="list-style-type: none"> <li>• Sealing rubber</li> </ul>	<ul style="list-style-type: none"> <li>• Check the rubber seal around the suction plate.</li> <li>• If necessary, clean the sealing rubber in the edge area, groove.</li> <li>• Do not stick the rubber seal to the suction plate</li> </ul>

	<ul style="list-style-type: none"> <li>• Check connection</li> </ul>	<ul style="list-style-type: none"> <li>• Check the connection between the vacuum hose and the suction plate.</li> <li>• Check that the connection is firmly tightened and cannot become loose.</li> </ul>
	<ul style="list-style-type: none"> <li>• Air filter</li> </ul>	<ul style="list-style-type: none"> <li>• Check the air filter, hose clamp connections etc. and ensure that they are all securely fastened.</li> </ul>
	<ul style="list-style-type: none"> <li>• Cables</li> </ul>	<ul style="list-style-type: none"> <li>• Check all vacuum pump lines for damage.</li> </ul>
	<ul style="list-style-type: none"> <li>• Cables</li> </ul>	<ul style="list-style-type: none"> <li>• Check that the cables do not rub against the housing</li> </ul>
	<ul style="list-style-type: none"> <li>• Foreign body</li> </ul>	<ul style="list-style-type: none"> <li>• Check that there is a vacuum at the vacuum pump and that no foreign objects have been sucked in</li> </ul>
<p>Load cannot be sucked in. Prescribed negative pressure can no longer be achieved. Negative pressure builds up too quickly when the appliance is switched off.</p>	<ul style="list-style-type: none"> <li>• Leak on suction plate due to dirt deposited between rubber seal and suction plate.</li> <li>• Sponge rubber seal worn or porous (ageing after exposure to UV radiation)</li> </ul>	<ul style="list-style-type: none"> <li>• Remove the rubber seal from the suction plate. Clean suction plate and slot in rubber seal. Replace the rubber seal on the suction plate and fasten it.</li> <li>• Replace the rubber seal if necessary.</li> </ul>



**For troubleshooting on the HE lifting unit, the BE-SPRINT-2 operating unit and the HONDA GXV engine, follow the instructions in the respective operating instructions!**



### 8.2.1 Mechanics

MAINTENANCE PERIOD	Work to be carried out
Initial inspection after 25 operating hours	<ul style="list-style-type: none"> <li>• Check or retighten all fixing screws (may only be carried out by a qualified person).</li> </ul>
Every 50 operating hours	<ul style="list-style-type: none"> <li>• Retighten all fixing screws (make sure that the screws are retightened according to the valid tightening torques of the corresponding strength classes).</li> <li>• Check all existing safety elements (such as folding pins) for proper function and replace defective safety elements. → 1)</li> <li>• Check all joints, guides, pins and sprockets, chains for proper function, readjust or replace if necessary.</li> <li>• Check gripper jaws (if present) for wear and clean, replace if necessary.</li> <li>• All existing sliding guides, rack gears and joints of moving parts or machine components must be greased / lubricated to reduce wear and for optimum movement sequences (recommended grease: Mobilgrease HXP 462).</li> <li>• Lubricate all grease nipples (if present) with grease gun.</li> </ul>
At least 1x per year (shorten the inspection interval in case of harsh operating conditions)	<ul style="list-style-type: none"> <li>• Inspection of all suspension parts, as well as bolts and brackets. Inspection for cracks, wear, corrosion and functional safety by an expert.</li> </ul>

1)

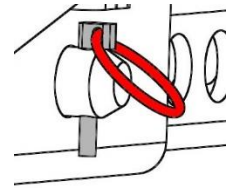
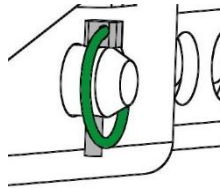





## 8.5 Hints to the type plate



- Type, serial-number and production year are very important for the identification of your device. If you need information to spare-parts, warranty or other specific details please refer to this information's.
- The maximum carrying capacity/working load limit (WLL) is the maximum load which can be handled with the device. **Do not** exceed this carrying capacity/working load limit (WLL).
- If you use the device in combination with other lifting equipment (Crane, chain hoist, forklift truck, excavator) consider the deadweight of the device.

XXX-XXX-XXX		
Art.-Nr.:	12345678	
SN:	31234567-00010-00001	
Baujahr/Year of manufacture:	20XX	
Eigengewicht/ Dead Weight:	00,000 kg/ 00,000 lbs	Probst GmbH Gottlieb-Daimler-Str. 6 20356 Germany Tel.: +49 7144 3300-0 www.probst-handling.com
Tragfähigkeit/ Working Load Limit:	00,000 kg/ 00,000 lbs	
Greifbereich/ Gripping Range:	0.000-0.000 mm/ 0,00-0,00 in	
Eintauchtiefe/ Inside Height:	0.000 mm/ 0000 in	
		 4 854979 583282

Example:

## 8.6 Hints to the renting/leasing of PROBST devices



With every renting/leasing of PROBST devices the **original operating instructions must be included** unconditionally (in deviation of the user's country's language, the respective translations of the original operating instructions must be delivered additionally)!

## 9 Disposal / recycling of devices and machines



The product **may only** be taken out of service and prepared for disposal / recycling by qualified personnel. Correspondingly existing **single components** (such as metals, plastics, liquids, batteries/rechargeable batteries etc.) **must** be disposed of/recycled in accordance with the nationally/country-specific applicable laws and **disposal regulations!**



**The product must not be disposed of in household waste!**

# Vacuum Hose Lifter Components

## Lifting hose unit with Operating Valve Unit

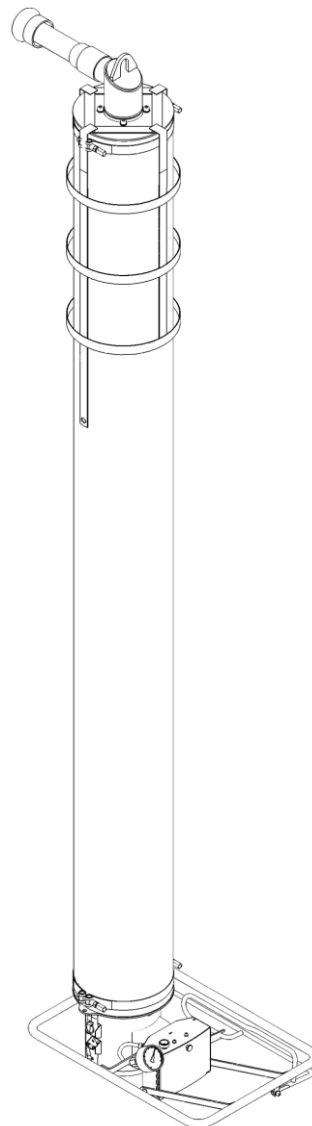

*Keep these Operating Instructions for future use !*

## Table of Contents

### 1 Safety

- 1.1 Instructions for the Company
- 1.2 Instructions for the Installation, Maintenance and Operating Personnel
- 1.3 Hazard Alert Symbols in this Manual
- 1.4 Installation Site Requirements
- 1.5 Intended Use
- 1.6 Emissions
- 1.7 Special Hazards
- 1.8 Workplace
- 1.9 Instructions for the Operator
- 1.10 Equipment for Personal Protection
- 1.11 Behaviour in Emergencies
- 1.12 Checking the Guards

### 2 Technical Data

### 3 Description

- 3.1 Components of the *JUMBO*
- 3.2 Rotary Suction Fitting
- 3.3 Lifting Tube
- 3.4 Control Unit
- 3.5 Accessories

### 4 Installation

- 4.1 Installation Procedure
- 4.2 Adjusting the Hovering Position (without load)
- 4.3 Replacing the lifting tube

### 5 Operating

- 5.1 Safety Instructions
- 5.2 Lifting, Lowering and Landing Loads

### 6 Trouble Shooting

### 7 Maintenance

- 7.1 General Notes
- 7.2 Cleaning
- 7.3 Accident prevention rules
- 7.4 Service-Table

### 8 Notes on the Name Plate

### 9 Storage

### 10 Guarantee, spare and consumable parts

**Special Features**

The unit is equipped with the following special feature(s):

.....

.....

.....

.....

.....

(See the Appendix for special operating instructions and spare parts.)

If the special features require a separate list of spare parts or parts subject of consumption, the corresponding list in section "Spare parts" is invalid.

## 1 Safety

### 1.1 Instructions for the Company

The *Vacuum Hose Lifter* has been manufactured according to current technological standards and is safe. Still, it will present hazards

- ⇒ if the device is not operated by qualified or, at least trained staff,
- ⇒ if the device is used contrary to the approved applications (see 1.5).

Problems can arise:

- ⇒ for the health and life of operators and other persons,
- ⇒ for the lifting device and other valuable goods.

### 1.2 Instructions for the Installation, Maintenance and Operating Personnel

The *Vacuum Hose Lifter* must be installed and maintained by qualified personnel, mechanics and electricians. Any work on the electrical equipment may be carried out only by a qualified electrician.

Each person in your company involved in the installation, start-up, operation, maintenance, and repair of the device must have read and understood the operating instructions and especially the chapters "Safety" and "Operating" therein.

Your company must ensure by internal measures

- ⇒ that the operators of the lifting device are properly trained,
- ⇒ that they have read and understood the operating instructions,
- ⇒ that the operating instructions will be available to them at any time.

The responsibilities for the tasks carried out with the device must be clearly organized and observed. Ambiguity regarding responsibilities must not exist. We recommend that you protect the lifting device from unauthorized use, e. g. by a key-switch.

### 1.3 Hazard Alert Symbols in this Manual



The hazard alert messages in this manual are labelled as follows:

Identifies imminent hazard. If you do not avoid it, death or severe injury will result.

Identifies a potentially hazardous situation. If you do not avoid it, minor or moderate injury can result.

### 1.4 Installation Site Requirements

The lifting device must not be operated in rooms with explosive atmosphere. If desired, the *Vacuum Hose Lifter* can be supplied in explosion-protected version.

The ambient temperature must be between +0°C and 40 °C (if this temperature may be exceeded, consult the manufacturer).

Ensure by internal instructions and checks that the installation site is always clean and well organized.



### 1.5 Intended Use



The *Vacuum Hose Lifter* is designed to lift and transport items of all kinds. The maximum lifting capacity must not be exceeded, however. Observe the name plate!

The loads must be stable enough that they cannot be destroyed during raising! Transport of persons and animals with the load or the lifting device itself is forbidden!

Unauthorized alteration of the lifting device is forbidden for safety reasons!



**Only suction plates** of the manufacturer **PROBST** shall be used!!!



Some suction plates which can be mounted to the device will reduce its carrying capacity.

The maximum load is **indicated** on each suction plate.

Use only suction plates which are approved for this device!

**Do not exceed** the maximum carrying capacity of the suction plates!!!

**Danger:** Load (stone slabs) will fall down!



The use of suction plates with a smaller **carrying capacity** than the lifting unit is **forbidden!** **Danger:** Load will fall down.

(It is permissible to use suction plates with a higher carrying capacity than the lifting unit).

The use of this device is only permitted in proximity to the ground.

The Load **must not** be lifted above **1,8 m** (70,8 inch)!

### 1.6 Emissions

The equivalent continuous sound pressure level amount in operation (workpiece sucked on) is for the *Vacuum Hose Lifter* below 70 dB (A).

### 1.7 Special Hazards

The load is held at the suction head by underpressure. If there is a sudden interruption of the vacuum generator, the underpressure at the suction head decreases. As a result the lifting tube of the device descends and the load lowers.

This happens in a sudden power failure. A non-return valve in the rotary suction fitting ensures that the vacuum can escape only slowly. However, this will work only when the regulator lever is moved to "Lift".

When power fails, immediately put the load down if possible. If this is not possible, immediately leave the dangerous area near the load.

The device generates a very strong suction which can draw in hair and clothing. Do not look into the suction opening or place small objects close to suction openings when the device is switched on.

### 1.8 Workplace



The workplace of the operator is in front of the control unit.

Make sure, that there will be no unauthorized operating of the main switch from the lifting device (for example with a padlock at the main switch).

Never stand below the load.

### 1.9 Instructions for the Operator

As an operator of the lifting device you must be trained before start-up. You must have read and understood the operating instructions and especially the chapters "Safety" and "Operating".

Be sure, that only authorized persons use the device. You are responsible for others in the operating range of the equipment.

Local safety requirements are fully applicable. Safety instructions in this document are complementary to the rules in force and do not supersede the latter.

**1.10 Equipment for Personal Protection** Wear safety shoes when operating the device.  
Before transporting dangerous goods the appropriate safety clothes have to be put on.

**1.11 Behaviour in Emergencies** As an example sudden power failure is an emergency (the device switches off invariably!).  
Turn the control handle fully to position "Lift". The operating unit lowers itself slowly with the load.

**1.12 Checking the Guards** A non-return valve is mounted inside the rotary suction fitting. It prevents the load from dropping off the vacuum head if there is a sudden power failure.  
Check the function of this non-return valve at the beginning of each shift (when operating in shifts) or once a week (when operating continually).  
During the check stay outside the dangerous area.  
When power fails, immediately put the load down if possible. If this is not possible, immediately leave the dangerous area near the load.  
Checking:  
⇒ Switch on the lifting device.  
⇒ Lift a load and turn the control handle fully to position "Lift".  
⇒ Switch off the lifting device. The device must lower itself slowly with the load.  
The load must not drop off at once.  
Correct faults before operating the device. If faults occur during operation, switch the device off and correct the faults before continuing work with the device.

## 2 Technical Data

Ambient temperature	0 - 40 °C
Max. lifting stroke	approx. 1550 mm

### 3 Description

#### 3.1 Components of the JUMBO

The *Vacuum Hose Lifter* consists essentially out of:

Pos.	Description	Remarks
1	Coupling	customer connection
2	Rotary suction fitting	customer connection
3	Lifting tube	customer connection
4	Operating unit	with regulator handle
5	Securing net	-
6	Covering for lifting tube	-

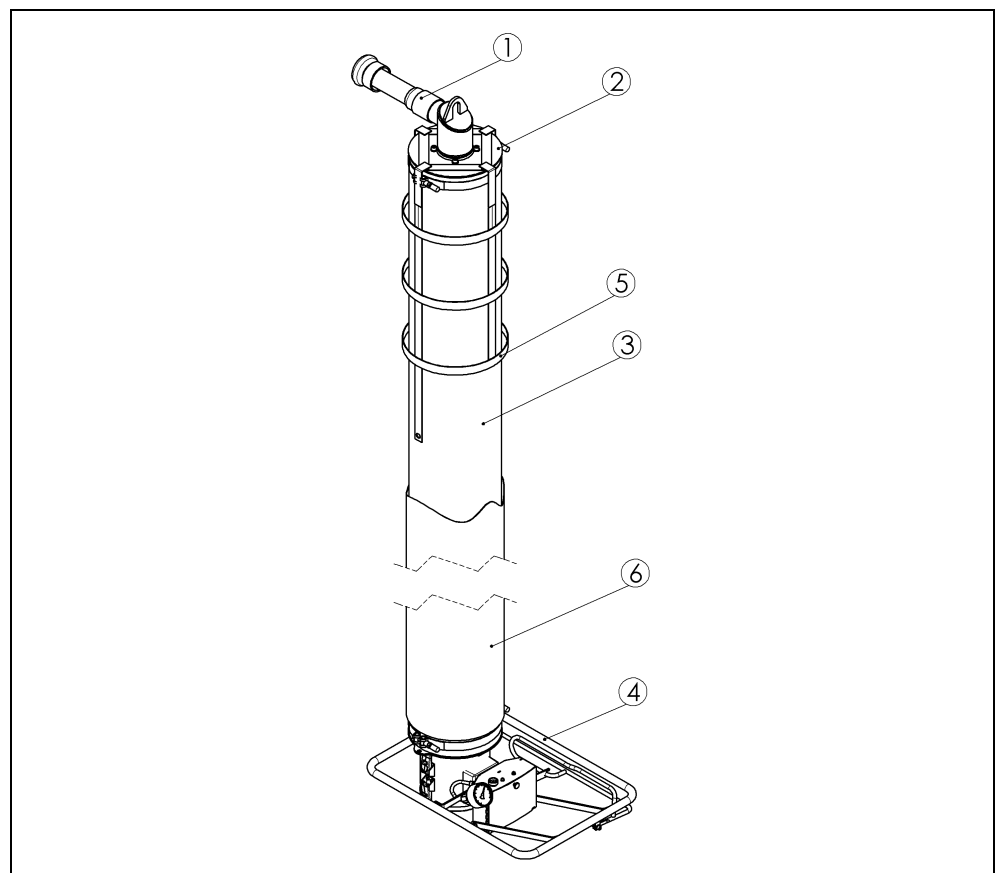

#### 3.2 Rotary Suction Fitting

The rotary suction fitting is connected to the suction hose of the blower and the lifting tube (3).

The lifting device is suspended on the rotary suction fitting.

The lifting device can be rotated endlessly.

#### 3.3 Lifting Tube

The lifting tube transmits the vacuum to the vacuum head(s) and realize the lifting movement of the lifting device.

#### 3.4 Control Unit

With the control unit the lifting and lowering of loads is controlled by changing the vacuum in the lifting device. It regulates the flow of outside air to the lifting unit.

The flow of outside air and therefore the vacuum is controlled by an orifice disc.

It is operated by a regulator lever (Pos. 4.2). The load is lifted when the control opening is fully closed by the slider. The farther the control opening is open, the more outside air will be drawn in. The load will lower.

### 3.5 Accessories

#### Dust Filter

The installation of a dust filter is urgently recommended to protect the fan from all kinds of dirt (dust from surroundings, dirty loads etc.)

Observe the enclosed installation instructions for dust filter.

Note: If no dust filter is used, foreign objects must be excluded from the guarantee as a possible cause of failure.

#### Motor Overload switch

With this device, the blower can be switched on and off. An integrated overcurrent switch prevents the blower motor from being damaged by high current.

#### Tube cylinder Extension

The tube cylinder extension is designed to handle parts in high-sided boxes, crates, wire-mesh boxes, etc. The tube cylinder extension has to be mounted between the vacuum head and the control unit.

#### Vacuum gauge

The vacuum gauge indicates the underpressure at the vacuum head and thereby the status of operation of the lifting device. It is mounted at the control unit.

#### Protection Tube

The protection tube is a protective covering for the lifting tube.

#### Retaining net

The retaining net is for space-saving storage of the lifting device. The length of the lifting tube is reduced to a minimum.

## 4 Installation

### 4.1 Installation Procedure

The *Vacuum Hose Lifter* must be installed and maintained by qualified personnel, mechanics and electricians. Any work on the electrical equipment may be carried out only by a qualified electrician.

#### Blower Installation

⇒ Install the vacuum blower as described in the separate operating instructions.

#### Checking the Rotation Direction

Before commissioning, check that the blower rotation direction corresponds with that in the separate manual.



When mounting the suction hose, observe that the hose is hanged up spirally turned ( $\varnothing$  at least 800 mm). Its length has to be the 1.3 to 1.5 times the jib length. The suction hose must hang down freely. It must not lie flat, rub or catch on anything.



- ⇒ Mount the rotary suction fitting (7) to the transport trailer (5) of the crane. Fasten it safely! Insert the transport trailer into the crane jib (2).
- ⇒ Mount the end stop (6) at the end of the crane jib. Never work without an end stop on the crane jib, otherwise the lifting device can fall off.
- ⇒ Connect the suction hose to the rotary suction fitting (4) and secure it with a hose clamp.

If you install the suction hose, note that the hose contracts under the pressure of vacuum by approximately 10 to 15 %. Therefore, a loose installation with length compensation should be provided. Longer, linear distances can also be bridged with a plastic pipe. The overall length should not exceed 50 m. Long suction hoses reduce the capacity and the dynamics of the tube lifter.

### 4.2 Adjusting the Hovering Position (without load)

The hovering position of the lifting device must be adapted to the weight of the vacuum head. A valve (2) in the tube support cylinder is used to adjust it. When you apply the vacuum head to the load a valve is fully opened by a plunger and the valve rod in the vacuum head. The load can be sucked and lifted.

Adjustment:

- ⇒ Turn the adjustment screw (1) at the operating unit (accessible from the bottom).
  - Turn clockwise (direction of arrow) → Valve becomes opened.
  - Turn counter-clockwise → Valve becomes closed.
- ⇒ The farther the valve is opened the lower the device hovers.



When the valve is closed totally the device bounce up abruptly as soon the blower is switched on!

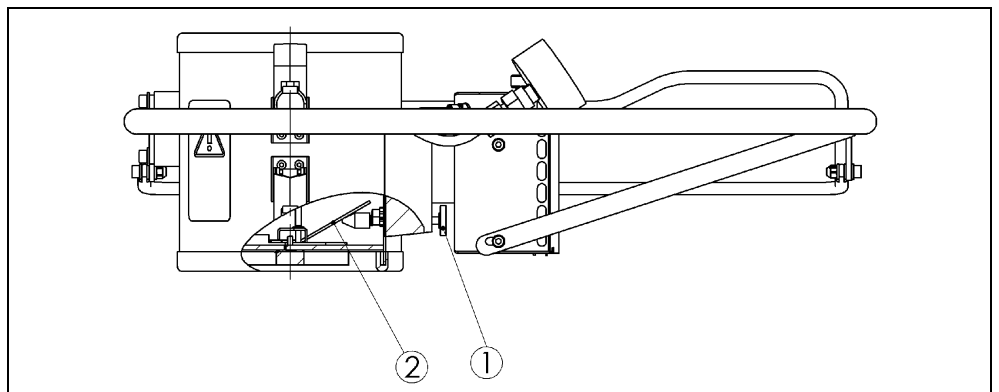

### 4.3 Replacing the lifting tube



The lifting tube can be replaced on-site.

The lifting tube must always be installed with the reinforced section at the bottom!

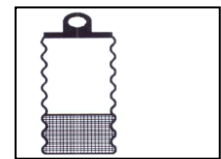

#### Procedure:

- ⇒ Clamp the rotary inlet in a vice, holding it by the screws of the tube holder (Fig. 1).
- ⇒ Remove the protective caps from the ends of the threads of the hose clamps.
- ⇒ Use a spanner to remove the hose clamps from the tube cylinder (Fig. 2) and the rotary inlet (Fig. 3).
- ⇒ Remove the adhesive tape from the old lifting tube.
- ⇒ Unscrew the old lifting tube from the tube mounting of the tube cylinder (Fig. 4).
- ⇒ Unscrew the lifting tube from the tube mounting of the rotary inlet (Fig. 5).
- ⇒ Lightly grease the threads of the tube mountings (Fig. 6).
- ⇒ Mount the new lifting tube with the reinforced section at the bottom!
- ⇒ Fully screw the new lifting tube onto the threads of the rotary inlet (Fig.7).
- ⇒ Fully screw the new lifting tube onto the threads of the tube cylinder (Fig. 8).
- ⇒ Wind tow full turns of adhesive tape (Coroplast) around the ends of the lifting tube to seal it to the tube cylinder (Fig. 9) and the rotary inlet (Figs. 10, 11).
- ⇒ Place the hose clamps on the ends of the lifting tube and tighten them with a torque of 10 Nm, using a torque wrench (Fig. 12).
- ⇒ Fit the protective caps on the ends of the threads of the hose clamps.



Fig. 1



Fig. 2



Fig. 3



Fig. 4



Fig. 5



Fig. 6



Fig. 7



Fig. 8



Fig. 9



Fig. 10



Fig. 11



Fig. 12

Serial number →  
Lifting tube dimension →



← Article number lifting tube



### 5 Operating

#### 5.1 Safety Instructions

Local safety requirements are fully applicable. The following safety instructions are complimentary to the rules in force and do not supersede the latter:

- ⇒ Wear safety shoes.
- ⇒ Before transporting dangerous goods the corresponding safety clothes have to be put on.
- ⇒ Never exceed the maximum lifting capacity of the lifting device. Observe the name plate on the handle.
- ⇒ Do not stand below the load. Always keep clear of the load.
- ⇒ Never carry people or animals with the load or the lifting device itself !
- ⇒ Operate only when you can view the entire working area. Look out for other persons in the working area.
- ⇒ Never manoeuvre loads above people.
- ⇒ Never lean about lifted loads.
- ⇒ Do not let go of the handle whilst lifting a load.
- ⇒ Do not pull loads to the side or drag them along with the lifting device.
- ⇒ Do not rip loose loads that have become jammed.
- ⇒ If there is a power failure immediately turn the handle (**JUMBOERGO**) resp. push upwards the regulator lever (**JUMBOSPRINT**) fully to "Lift" to prevent the load from dropping off. The reserve vacuum will let the lifting device lower slowly with the load.
- ⇒ Apply suction and lift only to appropriate loads (check for stability and porosity).
- ⇒ The lifting device is mounted into the crane rails with rail end stops. While moving against the rail end stops, strong horizontal forces can occur. These forces can result in releasing the load.



**If the lifting unit (lifting tube) is not able to lift the vacuum-gripped load, never try to support the lifting of the load, it is possible that the gripper's holding force is inadequate.**

**The load could fall → risk of injury.**

#### 5.2 Lifting, Lowering and Landing Loads

The following operating steps must be checked by a qualified mechanic prior to use of the device by the operating personnel. Correct faults before start-up.



The hovering position (without load) must be adjusted prior to start up, see 4.2.

Lifting

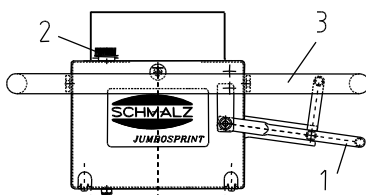

- ⇒ Place the vacuum head directly above the load.
- ⇒ Press the regulator lever (1) down. The lifting tube descends and the vacuum head lowers.
- ⇒ Apply the vacuum head to the load. Distribute load evenly.
- ⇒ Slowly push the regulator lever (1) upward. The device attaches to the load.

**Attention:** the regulator lever must not be on the position "Lift" for more than 90 seconds because otherwise:

- ⇒ the blower could be damaged and fail, all guarantee claims are void!
- ⇒ power is wasted unnecessarily.





### Adjusting the hovering position with load

Turn the adjusting screw (2) to adjust the hovering position with the load.  
**Caution:** Do not confuse this adjustment with the hovering position without load.

- ⇒ Turn screw clockwise → the hovering position will be lower.
- ⇒ Turn screw counter-clockwise → the hovering position will be higher.



**Attention:** the hovering position with load should not be adjusted to the highest position of the control unit because otherwise:

- ⇒ the blower could be damaged and fail, all guarantee claims are void!
- ⇒ power is wasted unnecessarily.

### Lowering, Placing



- ⇒ Slowly move the regulator lever (1) downward - "Lower". The lifting tube descends and the vacuum head lowers with the load. Do not operate the regulator lever control abruptly, while you firmly hold the handlebar (3), as this can cause the load to fall off, because the vacuum suddenly vanishes.
- ⇒ Lower the load to the chosen position.
- ⇒ To land the load push the regulator lever down all the way. Tip the valve control box a little and lift it off the load.

### 6 Trouble Shooting

The device must be installed and maintained by qualified personnel, mechanics and electricians. Any work on the electrical equipment may be carried out only by a qualified electrician.

After each repair or maintenance job check the guards as described in the Operating Manual "Safety".

**If a load cannot be lifted**, check through the following list to find the problem and correct it.

Error	Remedy
Opposite direction of rotation	⇒ Transpose the phases of the blower connection.
The required vacuum is not reached	⇒ Check the suction hose and tube lifter for airtightness. ⇒ Check the mounting of the suction heads ⇒ Clean resp. replace the dust filter cartridge
The load is too heavy	Split the load, use other lifting device.
The load is too porous or of low bending strength	Load cannot be lifted, try using a different vacuum head.
Suction hose is damaged	Replace hose or cut out damaged piece and connect remaining hose with a tube and hose clamps
Vacuum lifting tube is damaged	Replace the vacuum lifting tube
Connection of the vacuum head is damaged	Check seal on the tube cylinder, replace it.
Vacuum head is damaged	Check seal on the vacuum head, replace it.
The load drop off when you lower it	Please contact the manufacturer
The vacuum is reached but the lifting device can not lift porous loads	Please contact the manufacturer
The control unit of the tube lifter hangs in the upper block position (with running blower) even without load and is not coming down by turning the handle or regulator lever	⇒ Turn the adjustment screw at the control unit clockwise ⇒ Clean or replace the dust filter of the control unit

## 7 Maintenance

### 7.1 General Notes

The *Vacuum Hose Lifter* may be installed and maintained only by qualified personnel such as mechanics and electricians.

After any repair or maintenance work, check the safety devices as described in the section "Safety".

### 7.2 Cleaning

The maintenance proceedings and intervals are described in the service-table. Use cleaning detergent to clean the device (do not use petrol (gasoline) or aggressive or corrosive fluids to clean the device. The vacuum lifting tube and the suction hose will otherwise become leaky or be destroyed).

Remove items and contaminations such as adhesives, glue, saw dust, dust etc. sticking to the vacuum heads at least once a week. Use glycerine to clean the seals. Immediately replace damaged vacuum heads (tears, holes, waves).

### 7.3 Accident prevention rules

Accident prevention rules require a yearly inspection of lifting device and crane by a qualified person.

### 7.4 Service-Table

	Interval				
	daily	weekly	monthly	1/2-yearly	yearly
<b>Tube Lifter</b>					
Is the lifting tube in good condition ( not porous, no scrubbing spots, no holes and with that tight)?			X		X
Is the fastening of the lifting tube correct (wire clips at the correct place, tightening )?					X
Can the rotary suction fitting be rotated easily itself?			X		X
Does the rotary handle resp. the control handle operates smooth?			X		X
Are all junctions fixed, hose band clips etc.?					X
Are the type- and the lifting- capacity label still on the machine?					X
Is the operating instruction still present and does the worker know of it?					X
Is the handle firm?					X
Is the filtermat still at the operator unit and is it cleaned?			X		X
Check supporting parts (such as the suspension of the device) on deformation, wear, rust or other damages.				X	
<b>Function</b>					
Can the device be lifted and lowered without weight easily ? (Adjusting the valve in the operating unit)			X		X
<b>JUMBOSPRINT:</b> Can the hovering position of the device with weight be adjusted easily ? (Adjusting the adjusting screw at the operating unit)					X
Does the non return valve work by power failure?			X		X
Check the general condition of the machine.					X

### 8 Notes on the Name Plate

On the nameplate the main data for the lifting device is indicated.  
 The nameplate is firmly connected to the device.  
 The nameplate contains the following information:

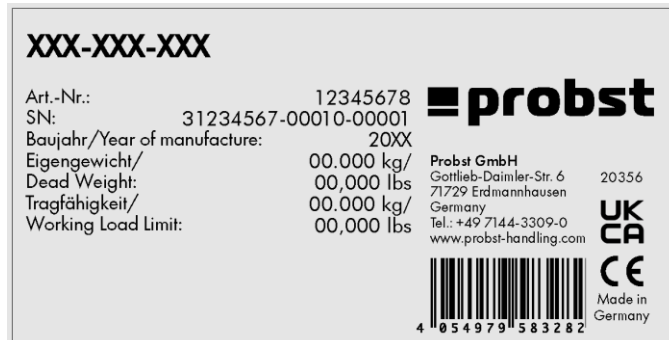

Type  
 Device number  
 Order number  
 Max. lifting capacity  
 Weight of device



Type and number are vital for identification of the unit. Indicate these when ordering spares or filing claims and other inquiries.

The max. lifting capacity indicates for which maximum load the device can be used. The max. load must not be exceeded.

### 9 Storage

If you are not using the Jumbo Sprint vacuum hose lifter, you should store it correctly to best preserve the product quality. This entails the following:

- ⇒ Clean the product (see 7.2) and let it dry if wet
- ⇒ Store the product in a room that protects it from moisture and frost (recommendation: in the manufacturer's storage case)
- ⇒ Storage temperature: +0 – 40 °C

To start up the system again, refer to chapter 4, "Installation"

### 10 Guarantee, spare and consumable parts

This equipment is guaranteed in accordance with our General Conditions of Business. This also applies to spare parts where these are original parts supplied by us.

We will assume no liability for damage caused by the use of non-original spare parts and accessories.

Wear and consumable parts are not covered by the guarantee.

The most important spare and consumable parts are shown in the following list.

- Abbreviations:
- Spare part = **E**
  - Consumable part = **V**
  - Consumable-part assembly, contains consumable parts = **VB**

Hubeinheit / Lifting Hose Assy

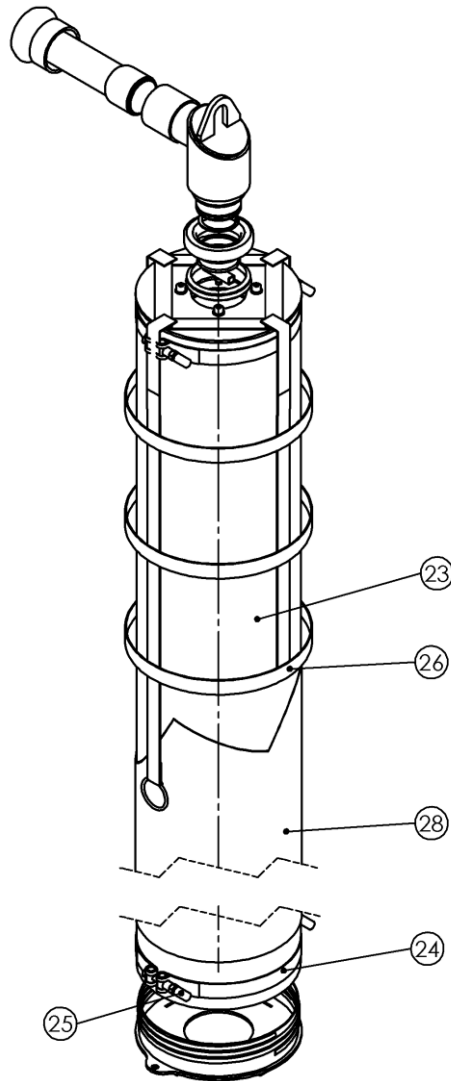

Dreheinheit / Rotation Unit

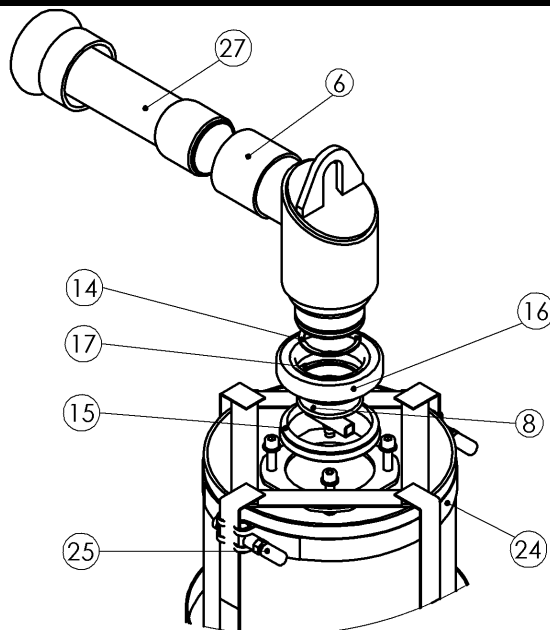



# Hubeinheit mit Bedieneinheit Ersatzteile/ /Spare Parts



Hubeinheit / Lifting Hose Assy						
Pos.	Menge / Amount	Bezeichnung	Description	Abmessung / Dimension	Art. No.	Legende
6	1	G 2" - L 56 - D 66,3	G 2" - L 56 - D 66,3		2700.0007	E
8	1	Flachsauggreifer_PFG	Flat suction pad_PFG		4210.0610	V
14	1	DIN 472 - 54 x 2,0	DIN 472 - 54 x 2,0		2048.0025	E
15	1	V-Ring	V-ring		4210.0611	V
16	1	Kugellager	Bearing		2135.0022	E
17	1	DIN 471 - 65 x 2,5	DIN 471 - 65 x 2,5		2048.0026	E
23	1	Hubschlauch	Lifting hose	PVC	2527.0010	V
24	2	Schlauchschele	Hose clamp	SSB	2105.0068	E
25	4	Kappe für SSB	Cap for SSB		2202.0042	E
26	1	Haltenetz	Securing net		2527.0005	V
27	1	Kupplung	Coupling		4200.0042	E
28	1	Schutzhülle	Covering for lifting tube		2529.0007	E

E= Ersatzteil, V= Verschleißteil, VB= Verschleißteilbaugruppe, enthält Verschleißteile

E= Spare part, V= Consumable part, VB= Consumable-part assembly, contains consumable parts

Hubeinheit / Lifting Hose Assy						
Pos.	HE 35-E/S-BP	HE 50-E/S-BP	HE 80-E/S-BP	HE 150-E/S-BP	HE 200-E/S-BP	HE 300-E/S-BP
23	11.04.01.10007	11.04.01.10028	11.04.01.10066	11.04.01.10178	11.04.01.10070	11.04.01.10129
24	10.07.10.00048	10.07.10.00049	10.07.10.00039	10.07.10.00046	10.07.10.00040	10.07.10.00065
26	11.01.12.10141	11.01.14.10058	11.01.05.10248	11.01.23.10043	11.01.25.10039	11.01.25.10084
28	11.04.01.10023	11.04.01.10018	11.04.01.10017	11.04.01.10132	11.04.01.10073	11.04.01.10127

E= Ersatzteil, V= Verschleißteil, VB= Verschleißteilbaugruppe, enthält Verschleißteile

E= Spare part, V= Consumable part, VB= Consumable-part assembly, contains consumable parts

Ventileinheit, Bedieneinheit / Valve Unit, Operating handle

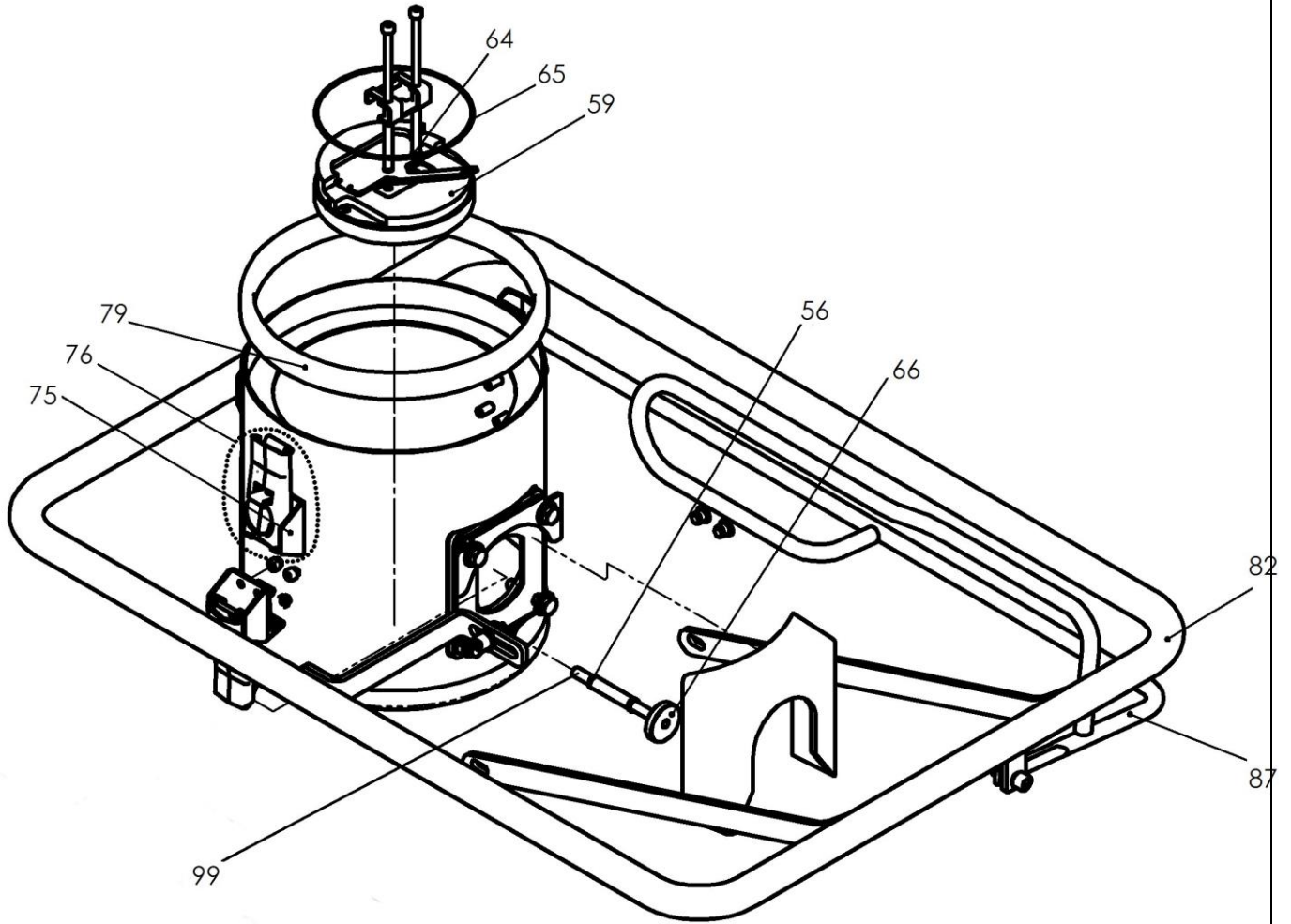

Ventileinheit / Valve Unit

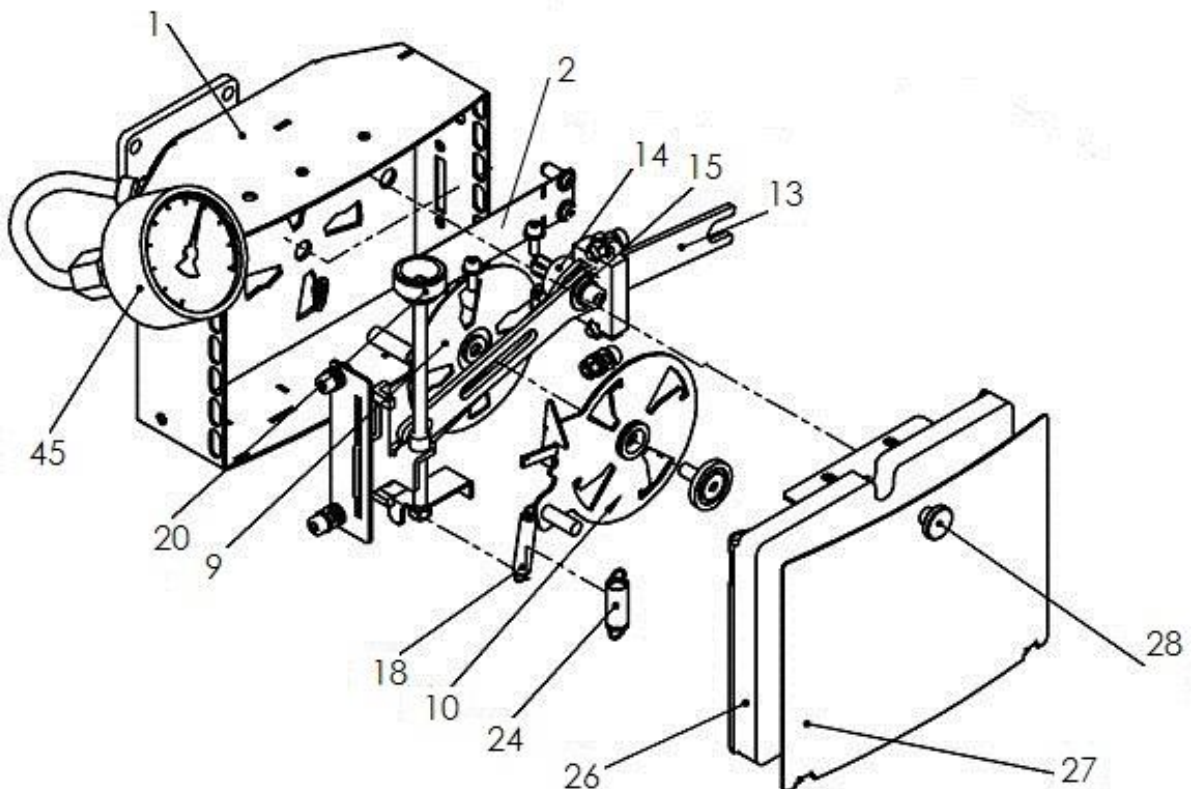

Ventileinheit, Bedieneinheit / Valve Unit, Operating handle						
Pos.	Menge / Amount	Bezeichnung	Description	Abmessung / Dimension	Art. No.	Legende
1	1	Ventilgehäuse kpl.	Valve casing compl.		4210.0612	E
2	1	Federklappe	Spring flap		4210.0608	E
9	1	Reibbelag	Friction lining		4210.0613	E
10	1	Scheibe	Disk		4210.0614	E
13	1	Schieber	Slide		4210.0401	E
14	1	Hülse	Socket for slide		4210.0535	E
15	1	Gleitlager	Bearing bush		4210.0536	E
18	1	Zugfeder	Tension spring	Z 066 OI	2171.0008	E
20	1	Stellschraube	Adjusting screw		4210.0403	E
24	1	Zugfeder	Tension spring	Z 081 HI	2171.0009	E
26	1	Filtermatte	Filter mat		2505.0010	V
27	1	Abdeckung f. Ventilklappe	Cover for valve unit		4210.0615	E
28	1	Rändelschraube	Knurled screw		2009.0038	E
45	1	Manometer VAM	Manometer VAM		2213.0007	E
56	1	Druckfeder	Spring (pressure)		2170.0044	E
59	1	Ventilklappe	Valve flap		4210.0558	E
64	2	Druckfeder	Spring (pressure)		2170.0045	E
65	1	O-Ring	O-ring seal		2155.0087	V
66	1	Rändelmutter	Knurled nut		2019.0021	E
75	4	Spannhaken für Spannverschluss	Tension hook		2106.0011	E
76	2	Spannverschluss	Tension lock		2106.0004	
79	2	Schlitzgummiring	Ruber seal		4210.0091	V
82	1	Haltebügel	Supporting strap		4210.0405	E
87	1	Reguliergriff	Control handle		4210.0406	E
99	1	Rundstab	Rod		4210.1051	E

E= Ersatzteil, V= Verschleißteil, VB= Verschleißteilbaugruppe, enthält Verschleißteile  
E= Spare part, V= Consumable part, VB= Consumable-part assembly, contains consumable parts







## INTRODUCTION

Thank you for purchasing a Honda engine. We want to help you to get the best results from your new engine and to operate it safely. This manual contains information on how to do that; please read it carefully before operating the engine. If a problem should arise, or if you have any questions about your engine, consult an authorized Honda servicing dealer.

All information in this publication is based on the latest product information available at the time of printing. Honda Motor Co., Ltd. reserves the right to make changes at any time without notice and without incurring any obligation. No part of this publication may be reproduced without written permission.

This manual should be considered a permanent part of the engine and should remain with the engine if resold.

Review the instructions provided with the equipment powered by this engine for any additional information regarding engine startup, shutdown, operation, adjustments or any special maintenance instructions.

United States, Puerto Rico, and U.S. Virgin Islands:

We suggest you read the warranty policy to fully understand its coverage and your responsibilities of ownership. The warranty policy is a separate document that should have been given to you by your dealer.

## SAFETY MESSAGES

Your safety and the safety of others is very important. We have provided important safety messages in this manual and on the engine. Please read these messages carefully.

A safety message alerts you to potential hazards that could hurt you or others. Each safety message is preceded by a safety alert symbol  and one of three words, DANGER, WARNING, or CAUTION.

These signal words mean:

 **DANGER** You WILL be KILLED or SERIOUSLY HURT if you don't follow instructions.

 **WARNING** You CAN be KILLED or SERIOUSLY HURT if you don't follow instructions.

 **CAUTION** You CAN be HURT if you don't follow instructions.

Each message tells you what the hazard is, what can happen, and what you can do to avoid or reduce injury.

## DAMAGE PREVENTION MESSAGES

You will also see other important messages that are preceded by the word NOTICE.

This word means:

 **NOTICE** Your engine or other property can be damaged if you don't follow instructions.

The purpose of these messages is to help prevent damage to your engine, other property, or the environment.

© 2005 Honda Motor Co., Ltd. — All Rights Reserved

GXV340UT2-GXV390UT1

32Z5N600  
00X32-Z5N-6000



ENGLISH

ENGLISH

# HONDA

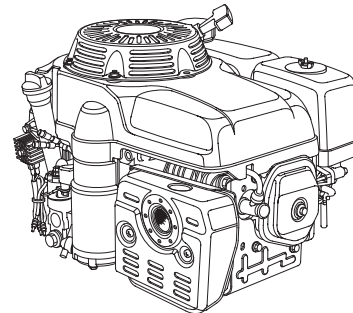
## OWNER'S MANUAL MANUEL DE L'UTILISATEUR MANUAL DEL PROPIETARIO GXV340 · GXV390



 **WARNING:**   
The engine exhaust from this product contains chemicals known to the State of California to cause cancer, birth defects or other reproductive harm.

## CONTENTS

INTRODUCTION.....1	SPARK PLUG.....10
SAFETY MESSAGES.....1	SPARK ARRESTER.....11
SAFETY INFORMATION.....2	HELPFUL TIPS & SUGGESTIONS.....11
SAFETY LABEL LOCATION.....2	STORING YOUR ENGINE.....11
COMPONENT & CONTROL LOCATION.....2	TRANSPORTING.....13
FEATURES.....3	TAKING CARE OF UNEXPECTED PROBLEMS.....13
BEFORE OPERATION CHECKS.....3	TECHNICAL & CONSUMER INFORMATION.....14
OPERATION.....4	Serial Number Location.....14
SAFE OPERATING PRECAUTIONS.....4	Battery Connections for Electric Starter.....14
STARTING THE ENGINE.....4	Remote Control Linkage.....14
STOPPING THE ENGINE.....5	Carburetor Modifications for High Altitude Operation.....14
SETTING ENGINE SPEED.....6	Oxygenated Fuels.....15
SERVICING YOUR ENGINE.....7	Emission Control System Information.....15
THE IMPORTANCE OF MAINTENANCE SAFETY.....7	Air Index.....16
SAFETY PRECAUTIONS.....7	Specifications.....16
MAINTENANCE SCHEDULE.....7	Tuneup Specifications.....16
REFUELING.....8	Quick Reference Information.....17
ENGINE OIL.....8	Wiring Diagrams.....17
Recommended Oil.....8	CONSUMER INFORMATION..18
Oil Level Check.....9	Distributor/Dealer Locator Information.....18
Oil Change.....9	Customer Service Information.....18
AIR CLEANER.....10	
Inspection.....10	
Cleaning.....10	

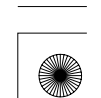
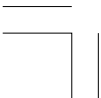



### SAFETY INFORMATION

- Understand the operation of all controls and learn how to stop the engine quickly in case of emergency. Make sure the operator receives adequate instruction before operating the equipment.
- Do not allow children to operate the engine. Keep children and pets away from the area of operation.
- Your engine's exhaust contains poisonous carbon monoxide. Do not run the engine without adequate ventilation, and never run the engine indoors.
- The engine and exhaust become very hot during operation. Keep the engine at least 1 meter (3 feet) away from buildings and other equipment during operation. Keep flammable materials away, and do not place anything on the engine while it is running.

### SAFETY LABEL LOCATION

This label warns you of potential hazards that can cause serious injury. Read it carefully. If the label comes off or becomes hard to read, contact your Honda dealer for replacement.



For Canadian types only:  
French label comes with the engine.

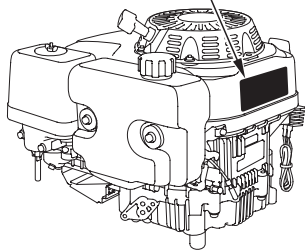

Gasoline is highly flammable and explosive. Turn engine off and let cool before refueling.



The engine emits toxic poisonous carbon monoxide gas. Do not run in an enclosed area.



Read Owner's Manual before operation.

### COMPONENT & CONTROL LOCATION

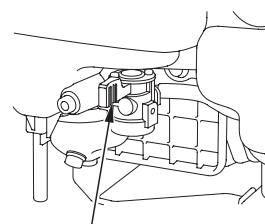
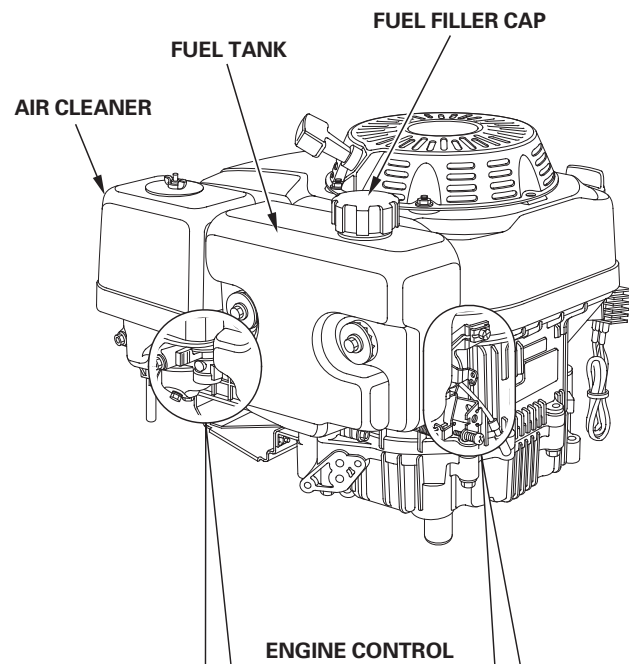
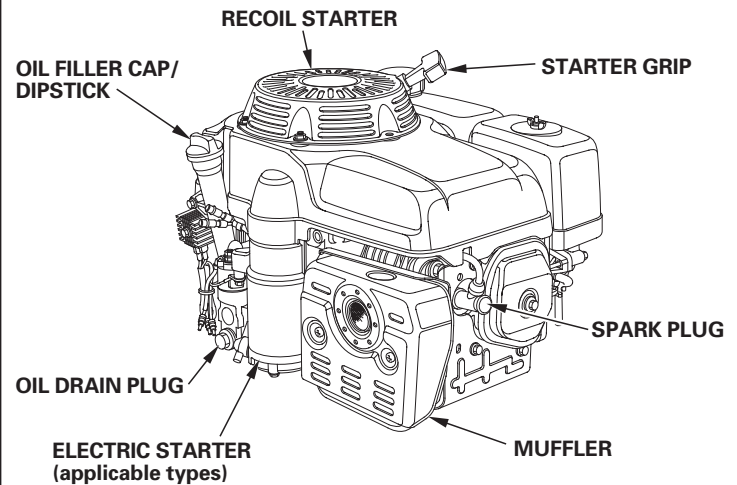

FUEL VALVE LEVER

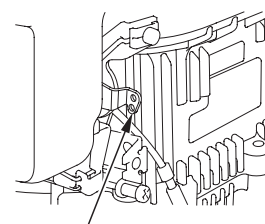

CONTROL LEVER



## FEATURES

### **OIL ALERT® SYSTEM (applicable types)**

The Oil Alert® system is designed to prevent engine damage caused by an insufficient amount of oil in the crankcase. Before the oil level in the crankcase can fall below a safe limit, the Oil Alert® system will sound a buzzer, warning you that oil needs to be added to the engine.

The Oil Alert® system is not designed to be used in place of checking the oil. Check the oil level prior to each use.

The "Oil Alert®" buzzer will arm you when engine oil needs to be added to the crankcase. If the buzzer sounds, stop the engine and add oil (see page 9).

#### **NOTICE**

*The buzzer indicates insufficient oil. Running the engine with insufficient oil can cause serious engine damage.*

## BEFORE OPERATION CHECKS

### **IS YOUR ENGINE READY TO GO?**

For your safety, and to maximize the service life of your equipment, it is very important to take a few moments before you operate the engine to check its condition. Be sure to take care of any problem you find, or have your servicing dealer correct it, before you operate the engine.

#### **⚠ WARNING**

Improperly maintaining this engine, or failure to correct a problem before operation, can cause a malfunction in which you can be seriously hurt or killed.

Always perform a preoperation inspection before each operation, and correct any problem.

Before beginning your preoperation checks, be sure the engine is level and the engine switch is in the OFF position.

Always check the following items before you start the engine:

#### **Check the General Condition of the Engine**

1. Look around and underneath the engine for signs of oil or gasoline leaks.
2. Remove any excessive dirt or debris, especially around the muffler and recoil starter.
3. Look for signs of damage.
4. Check that all shields and covers are in place, and all nuts, bolts, and screws are tightened.

#### **Check the Engine**

1. Check the fuel level (see page 8 ). Starting with a full tank will help to eliminate or reduce operating interruptions for refueling.
2. Check the engine oil level (see page 9 ). Running the engine with a low oil level can cause engine damage.

The "Oil Alert®" buzzer (applicable types) will warn you when engine oil needs to be added to the crankcase. If the buzzer sounds, stop the engine and add oil.

3. Check the air filter element (see page 10 ). A dirty air filter element will restrict air flow to the carburetor, reducing engine performance.
4. Check the equipment powered by this engine.

Review the instructions provided with the equipment powered by this engine for any precautions and procedures that should be followed before engine startup.



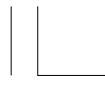

## OPERATION

### SAFE OPERATING PRECAUTIONS

Before operating the engine for the first time, please review the *SAFETY INFORMATION* section on page 2 and the *BEFORE OPERATION CHECKS* on page 3.

#### **⚠ WARNING**

Carbon monoxide gas is toxic. Breathing it can cause unconsciousness and even kill you.

Avoid any areas or actions that expose you to carbon monoxide.

Review the instructions provided with the equipment powered by this engine for any safety precautions that should be observed with engine startup, shutdown or operation.

#### Control Lever

The control lever operates the engine switch, throttle, and choke.

**OFF** ----- Stop the engine by switching off the ignition system. All other control lever positions leave the ignition system switched on.

**MIN.** ----- For running the engine at idle speed.

**MAX.** ----- For restarting a warm engine, and for running the engine at maximum speed.

**CHOKE** ----- Enriches the fuel mixture for starting a cold engine.

The control lever shown here will be connected to a remote control on the equipment powered by this engine. Refer to the instructions provided with that equipment for remote control information.

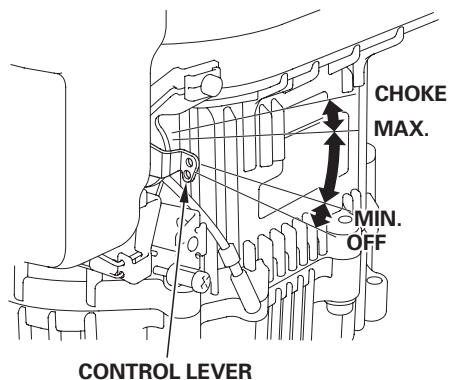

### STARTING THE ENGINE

1. Move the fuel valve lever to the ON position.

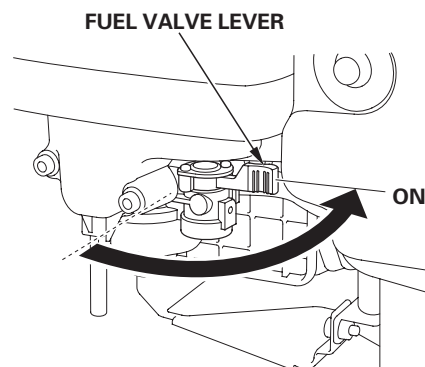

2. To start a cold engine, move the control lever to the CHOKE position.

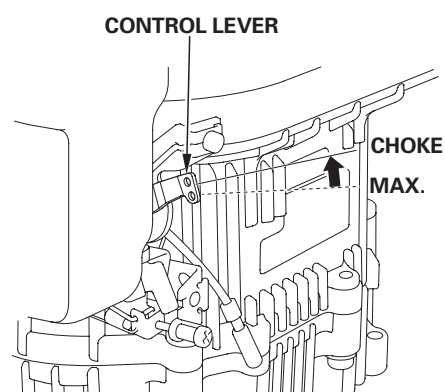

To restart a warm engine, leave the control lever in the MAX. position.

The control lever shown here will be connected to a remote control on the equipment powered by this engine. Refer to the instructions provided with that equipment for remote control information.

3. Turn the engine switch to the ON position.

There may be a remote engine switch mounted on the equipment powered by this engine. Refer to the instructions provided with the equipment for remote control information.

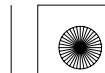

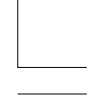

4. Operate the starter.

RECOIL STARTER

Pull the starter grip lightly until you feel resistance, then pull briskly. Return the starter grip gently.

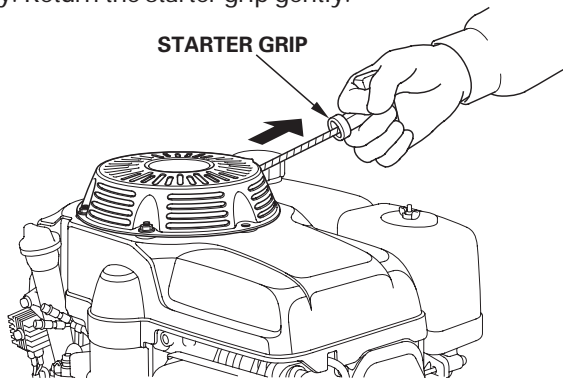

**NOTICE**

*Do not allow the starter grip to snap back against the engine. Return it gently to prevent damage to the starter.*

ELECTRIC STARTER (applicable types):

The electric starter will be connected to a remote control on the equipment powered by this engine. Refer to the instructions provided with the equipment for remote control information.

Turn the engine switch key to the START position, and hold it there until the engine starts.

If the engine fails to start within 5 seconds, release the engine switch key, and wait at least 10 seconds before operating the starter again.

**NOTICE**

*Using the electric starter for more than 5 seconds at a time will overheat the starter motor and can damage it.*

When the engine starts, release the engine switch key, allowing it to return to the ON position.

5. If the control lever was moved to the CHOKE position to start the engine, gradually move it to the MAX. or MIN. position as the engine warms up.

The control lever shown here will be connected to a remote control on the equipment powered by this engine. Refer to the instructions provided with that equipment for remote control information.

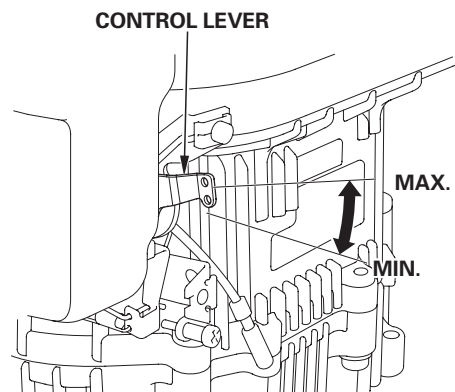

**STOPPING THE ENGINE**

To stop the engine in an emergency, simply move the control lever to the OFF position. Under normal conditions, use the following procedure.

1. Move the control lever to the OFF position.

The control lever shown here will be connected to a remote control on the equipment powered by this engine. Refer to the instructions provided with the equipment for remote control information.

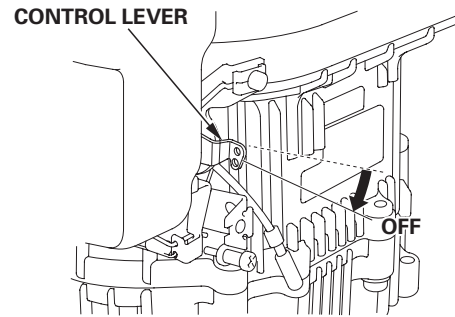

2. Turn the engine switch to the OFF position.

There may be a remote engine switch mounted on the equipment powered by this engine. Refer to the instructions provided with the equipment for remote control information.

3. Turn the fuel valve lever to the OFF position.

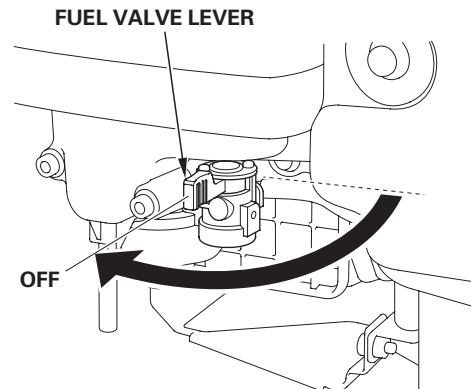



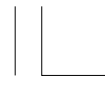

### SETTING ENGINE SPEED

Position the control lever for the desired engine speed.

The control lever shown here will be connected to a remote control on the equipment powered by this engine. Refer to the instructions provided with that equipment for remote control information and engine speed recommendations.

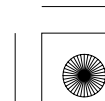
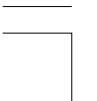
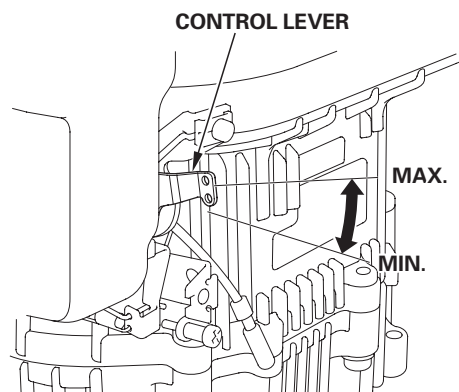



## SERVICING YOUR ENGINE

### THE IMPORTANCE OF MAINTENANCE

Good maintenance is essential for safe, economical and trouble-free operation. It will also help reduce pollution.

#### **⚠ WARNING**

Improper maintenance, or failure to correct a problem before operation, can cause a malfunction in which you can be seriously hurt or killed.

Always follow the inspection and maintenance recommendations and schedules in this owner's manual.

To help you properly care for your engine, the following pages include a maintenance schedule, routine inspection procedures, and simple maintenance procedures using basic hand tools. Other service tasks that are more difficult, or require special tools, are best handled by professionals and are normally performed by a Honda technician or other qualified mechanic.

The maintenance schedule applies to normal operating conditions. If you operate your engine under severe conditions, such as sustained high-load or high-temperature operation, or use in unusually wet or dusty conditions, consult your servicing dealer for recommendations applicable to your individual needs and use.

**Maintenance, replacement, or repair of the emission control devices and systems may be performed by any engine repair establishment or individual, using parts that are "certified" to EPA standards.**

### MAINTENANCE SAFETY

Some of the most important safety precautions follow. However, we cannot warn you of every conceivable hazard that can arise in performing maintenance. Only you can decide whether or not you should perform a given task.

#### **⚠ WARNING**

Failure to properly follow maintenance instructions and precautions can cause you to be seriously hurt or killed.

Always follow the procedures and precautions in this owner's manual.

### SAFETY PRECAUTIONS

- Make sure the engine is off before you begin any maintenance or repairs. This will eliminate several potential hazards:
  - **Carbon monoxide poisoning from engine exhaust.** Be sure there is adequate ventilation whenever you operate the engine.
  - **Burns from hot parts.** Let the engine and exhaust system cool before touching.
  - **Injury from moving parts.** Do not run the engine unless instructed to do so.
- Read the instructions before you begin, and make sure you have the tools and skills required.
- To reduce the possibility of fire or explosion, be careful when working around gasoline. Use only a nonflammable solvent, not gasoline, to clean parts. Keep cigarettes, sparks and flames away from all fuel related parts.

Remember that an authorized Honda servicing dealer knows your engine best and is fully equipped to maintain and repair it. To ensure the best quality and reliability, use only new genuine Honda parts or their equivalents for repair and replacement.

## MAINTENANCE SCHEDULE

REGULAR SERVICE PERIOD (3) Perform at every indicated month or operating hour interval, whichever comes first.		Each Use	First Month or 20 Hrs	Every 3 Months or 50 Hrs	Every 6 Months or 100 Hrs	Every Year or 300 Hrs	Refer to Page
ITEM							
Engine oil	Check level	○					9
	Change		○		○		9
Air filter	Check	○					10
	Clean			○ (1)			
	Replace					○ *	
Spark plug	Check-adjust				○		10
	Replace					○	
Spark arrester (applicable types)	Clean				○		11
Idle speed	Check-adjust					○ (2)	Shop manual
Valve clearance	Check-adjust					○ (2)	Shop manual
Combustion chamber	Clean	After every 250 Hrs. (2)					Shop manual
Fuel tank & filter	Clean					○ (2)	Shop manual
Fuel tube	Check	Every 2 years (Replace if necessary) (2)					Shop manual

\* Replace paper element type only.

- (1) Service more frequently when used in dusty areas.
- (2) These items should be serviced by your servicing dealer, unless you have the proper tools and are mechanically proficient. Refer to Honda shop manual for service procedures.
- (3) For commercial use, log hours of operation to determine proper maintenance intervals.

Failure to follow this maintenance schedule could result in non-warrantable failures.





## REFUELING

### Recommended Fuel

Unleaded gasoline	
U.S.	Pump octane rating 86 or higher
Except U.S.	Research octane rating 91 or higher Pump octane rating 86 or higher

This engine is certified to operate on unleaded gasoline. Unleaded gasoline produces fewer engine and spark plug deposits and extends exhaust system life.

### ⚠ WARNING

Gasoline is highly flammable and explosive, and you can be burned or seriously injured when refueling.

- Stop engine and keep heat, sparks, and flame away.
- Refuel only outdoors.
- Wipe up spills immediately.

### NOTICE

Fuel can damage paint and some types of plastic. Be careful not to spill fuel when filling your fuel tank. Damage caused by spilled fuel is not covered under the Distributor's Limited Warranty.

Never use stale or contaminated gasoline or oil/gasoline mixture. Avoid getting dirt or water in the fuel tank.

Occasionally you may hear a light "spark knock" or "pinging" (metallic rapping noise) while operating under heavy loads. This is no cause for concern.

If spark knock or pinging occurs at a steady engine speed, under normal load, change brands of gasoline. If spark knock or pinging persists, see an authorized Honda servicing dealer.

### NOTICE

Running the engine with persistent spark knock or pinging can cause engine damage.

Running the engine with persistent spark knock or pinging is considered misuse, and the Distributor's Limited Warranty does not cover parts damaged by misuse.

1. With the engine stopped and on a level surface, remove the fuel filler cap and check the fuel level.
2. Refill the tank if the fuel level is low. Do not fill above the upper limit of the fuel tank. Wipe up spilled fuel before starting the engine.

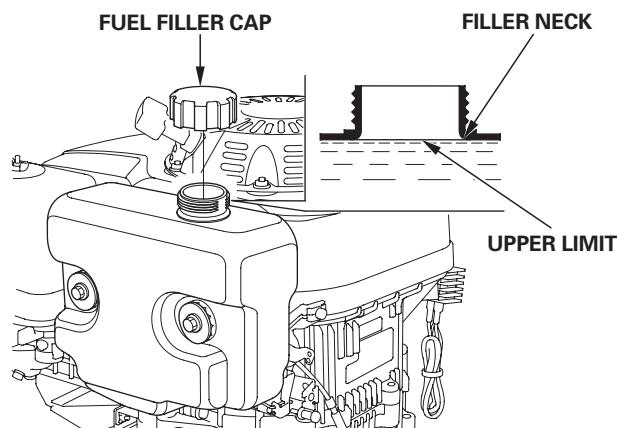

Refuel in a well-ventilated area before starting the engine. If the engine has been running, allow it to cool. Refuel carefully to avoid spilling fuel. Do not fill the fuel tank completely. Fill tank to the upper limit level below the filler neck of the fuel tank to allow for fuel expansion. It may be necessary to lower the fuel level depending on operating conditions. After refueling, tighten the fuel filler cap securely.

Never refuel the engine inside a building where gasoline fumes may reach flames or sparks. Keep gasoline away from appliance pilot lights, barbecues, electric appliances, power tools, etc.

Spilled fuel is not only a fire hazard, it causes environmental damage. Wipe up spills immediately.

For information regarding oxygenated fuels, please refer to page 15.

## ENGINE OIL

Oil is a major factor affecting performance and service life. Use 4-stroke automotive detergent oil.

### Recommended Oil

Use 4-stroke motor oil that meets or exceeds the requirements for API service classification SJ, SL, or equivalent. Always check the API service label on the oil container to be sure it includes the letters SJ, SL, or equivalent.

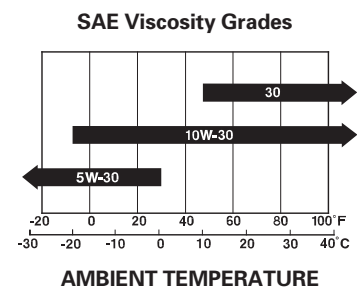

SAE 10W-30 is recommended for general use. Other viscosities shown in the chart may be used when the average temperature in your area is within the indicated range.



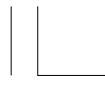

### Oil Level Check

Check the engine oil level with the engine stopped and in a level position.

1. Remove the oil filler cap/dipstick and wipe it clean.
2. Insert and remove the oil filler cap/dipstick without screwing it into the oil filler neck. Check the oil level shown on the dipstick.
3. If the oil level is near or below the lower limit mark on the dipstick, fill with the recommended oil (see page 8) to the upper limit mark. Do not overfill.
4. Screw in the filler cap/dipstick securely.

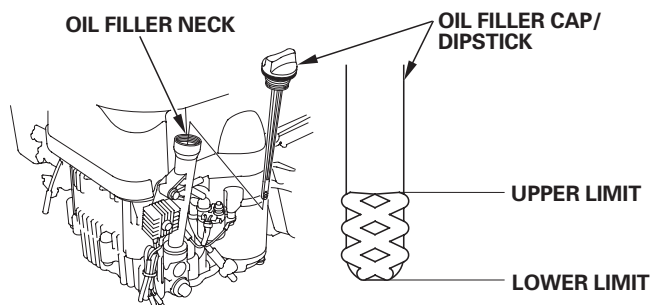

#### NOTICE

*Running the engine with a low oil level can cause engine damage.*

The "Oil Alert®" buzzer (applicable types) will warn you when engine oil needs to be added to the crankcase. If the buzzer sounds, stop the engine and add oil.

### Oil Change

Drain the used oil when the engine is warm. Warm oil drains quickly and completely.

1. Place a suitable container below the engine to catch the used oil, then remove the oil filler cap/dipstick, oil drain plug and washer.
2. Allow the used oil to drain completely, then reinstall the oil drain plug and new washer, and tighten the oil drain plug securely.

Please dispose of used motor oil in a manner that is compatible with the environment. We suggest you take used oil in a sealed container to your local recycling center or service station for reclamation. Do not throw it in the trash, pour it on the ground, or down a drain.

3. With the engine in a level position, fill to the upper limit mark on the dipstick with the recommended oil (see page 8).

#### NOTICE

*Running the engine with a low oil level can cause engine damage.*

The "Oil Alert®" buzzer (applicable types) will warn you when engine oil needs to be added to the crankcase. If the buzzer sounds, stop the engine and add oil.

4. Screw in the oil filler cap/dipstick securely.

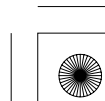
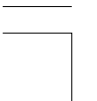
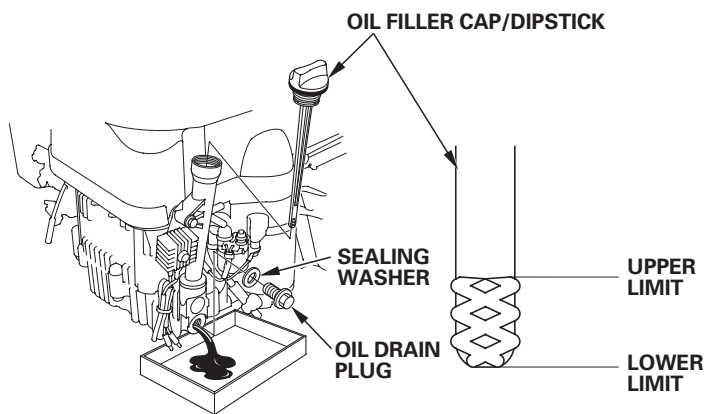



## AIR CLEANER

A dirty air cleaner will restrict air flow to the carburetor, reducing engine performance. If you operate the engine in very dusty areas, clean the air filter more often than specified in the MAINTENANCE SCHEDULE.

### NOTICE

*Operating the engine without an air filter, or with a damaged air filter, will allow dirt to enter the engine, causing rapid engine wear. This type of damage is not covered by the Distributor's Limited Warranty.*

### Inspection

Remove the air cleaner cover and inspect the filter elements. Clean or replace dirty filter elements. Always replace damaged filter elements.

### Cleaning

1. Remove the wing nut from the air cleaner cover, and remove the cover.
2. Remove the air filter elements.
3. Remove the foam air filter element from the paper air filter element.
4. Inspect both air filter elements, and replace them if they are damaged. Always replace the paper air filter element at the scheduled interval (see page 7).

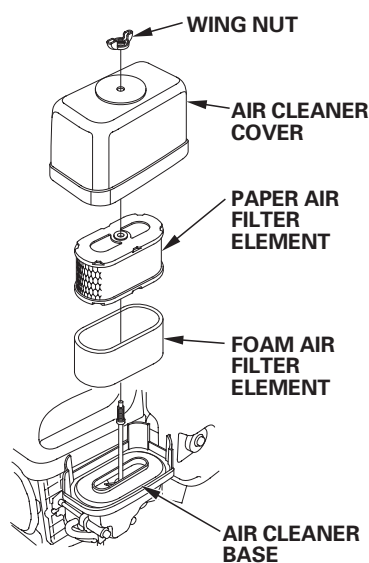

5. Clean the air filter elements if they are to be reused.

**Paper air filter element:** Tap the filter element several times on a hard surface to remove dirt, or blow compressed air [not exceeding 207 kPa (2.1 kgf/cm<sup>2</sup>, 30 psi)] through the filter element from the inside. Never try to brush off dirt; brushing will force dirt into the fibers.

**Foam air filter element:** Clean in warm soapy water, rinse, and allow to dry thoroughly. Or clean in nonflammable solvent and allow to dry. Dip the filter element in clean engine oil, then squeeze out all excess oil. The engine will smoke when started if too much oil is left in the foam.

6. Wipe dirt from the inside of the air cleaner base and cover, using a moist rag. Be careful to prevent dirt from entering the air duct that leads to the carburetor.
7. Place the foam air filter element over the paper element, and reinstall the assembled air filter.
8. Install the air cleaner cover, and tighten the wing nut securely.

## SPARK PLUG

**Recommended Spark Plugs:** BPR5ES (NGK)  
W16EPR-U (DENSO)

The recommended spark plug is the correct heat range for normal engine operating temperatures.

### NOTICE

*An incorrect spark plug can cause engine damage.*

For good performance, the spark plug must be properly gapped and free of deposits.

1. Disconnect the spark plug cap, and remove any dirt from around the spark plug area.
2. Remove the spark plug with a 13/16-inch spark plug wrench.

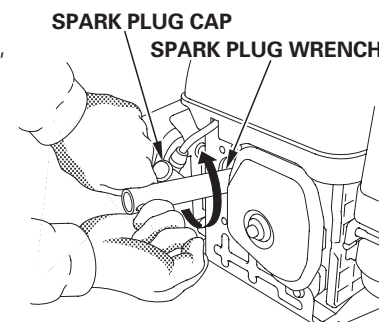

3. Inspect the spark plug. Replace it if damaged, badly fouled, if the sealing washer is in poor condition, or if the electrode is worn.

4. Measure the spark plug electrode gap with a wire-type feeler gauge. Correct the gap, if necessary, by carefully bending the side electrode. The gap should be: 0.70–0.80 mm (0.028–0.031 in)

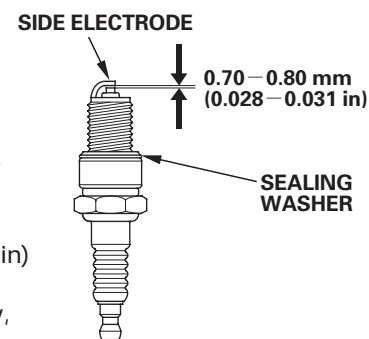

5. Install the spark plug carefully, by hand, to avoid cross-threading.
6. After the spark plug is seated, tighten with a 13/16-inch spark plug wrench to compress the sealing washer.
7. When installing a new spark plug, tighten 1/2 turn after the spark plug seats to compress the washer.
8. When reinstalling the original spark plug, tighten 1/8–1/4 turn after the spark plug seats to compress the washer.

### NOTICE

*A loose spark plug can overheat and damage the engine. Overtightening the spark plug can damage the threads in the cylinder head.*

9. Attach the spark plug cap to the spark plug.







### SPARK ARRESTER (applicable types)

The spark arrester may be standard or an optional part, depending on the engine type. In some areas, it is illegal to operate an engine without a spark arrester. Check local laws and regulations. A spark arrester is available from authorized Honda servicing dealers.

The spark arrester must be serviced every 100 hours to keep it functioning as designed.

If the engine has been running, the muffler will be hot. Allow it to cool before servicing the spark arrester.

#### Spark Arrester Removal

1. Remove the three 5 mm screws from the muffler protector.
2. Remove the 8 mm bolt and the two 8 mm nuts, and remove the muffler protector, identification plate, muffler and gasket from the cylinder.
3. Remove the spark arrester from the muffler (take care not to damage the wire mesh).

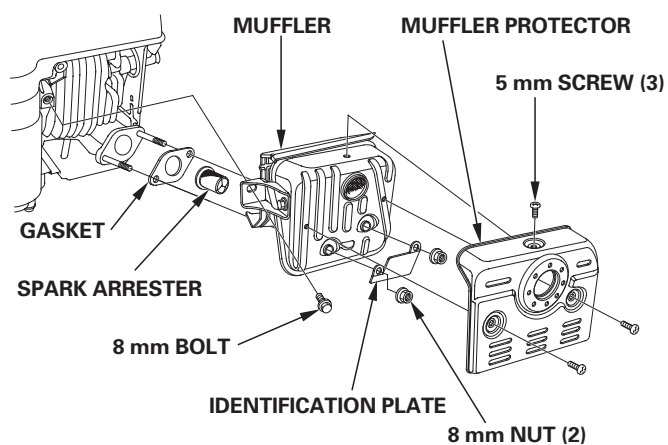

#### Spark Arrester Cleaning & Inspection

1. Use a brush to remove carbon deposits from the spark arrester screen. Be careful not to damage the screen. Replace the spark arrester if it has breaks or holes.
2. Install the gasket, spark arrester, muffler, identification plate, and muffler protector in reverse order of removal.



## HELPFUL TIPS & SUGGESTIONS

### STORING YOUR ENGINE

#### Storage Preparation

Proper storage preparation is essential for keeping your engine trouble-free and looking good. The following steps will help to keep rust and corrosion from impairing your engine's function and appearance, and will make the engine easier to start when you use it again.

#### Cleaning

If the engine has been running, allow it to cool for at least half an hour before cleaning. Clean all exterior surfaces, touch up any damaged paint, and coat other areas that may rust with a light film of oil.

#### NOTICE

*Using a garden hose or pressure washing equipment can force water into the air cleaner or muffler opening. Water in the air cleaner will soak the air filter, and water that passes through the air filter or muffler can enter the cylinder, causing damage.*

#### Fuel

Gasoline will oxidize and deteriorate in storage. Deteriorated gasoline will cause hard starting, and it leaves gum deposits that clog the fuel system. If the gasoline in your engine deteriorates during storage, you may need to have the carburetor, and other fuel system components, serviced or replaced.

The length of time that gasoline can be left in your fuel tank and carburetor without causing functional problems will vary with such factors as gasoline blend, your storage temperatures, and whether the fuel tank is partially or completely filled. The air in a partially filled fuel tank promotes fuel deterioration. Very warm storage temperatures accelerate fuel deterioration. Fuel problems may occur within a few months, or even less if the gasoline was not fresh when you filled the fuel tank.

Fuel system damage or engine performance problems resulting from neglected storage preparation are not covered under the *Distributor's Limited Warranty*.

You can extend fuel storage life by adding a gasoline stabilizer that is formulated for that purpose, or you can avoid fuel deterioration problems by draining the fuel tank and carburetor.





### Adding a Gasoline Stabilizer to Extend Fuel Storage Life

When adding a gasoline stabilizer, fill the fuel tank with fresh gasoline. If only partially filled, air in the tank will promote fuel deterioration during storage. If you keep a container of gasoline for refueling, be sure that it contains only fresh gasoline.

1. Add gasoline stabilizer following the manufacturer's instructions.
2. After adding a gasoline stabilizer, run the engine outdoors for 10 minutes to be sure that treated gasoline has replaced the untreated gasoline in the carburetor.
3. Stop the engine, and move the fuel valve lever to the OFF position.

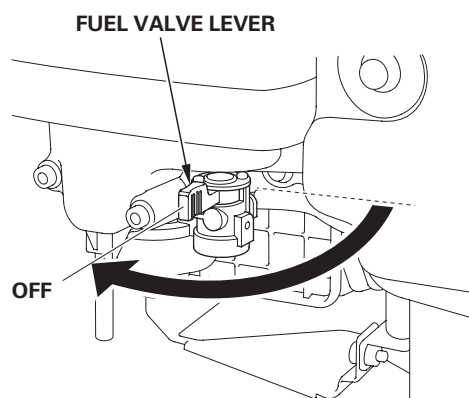

### Draining the Fuel Tank and Carburetor

#### ⚠ WARNING

Gasoline is highly flammable and explosive, and you can be burned or seriously injured when handling fuel.

- Stop engine and keep heat, sparks, and flame away.
- Handle fuel only outdoors.
- Wipe up spills immediately.

1. Place an approved gasoline container below the carburetor, and use a funnel to avoid spilling fuel.
2. Remove the drain bolt and gasket, and drain the carburetor bowl fuel into an approved gasoline container.
3. Move the fuel valve lever to the ON position. This will allow the fuel tank to drain through the carburetor bowl.

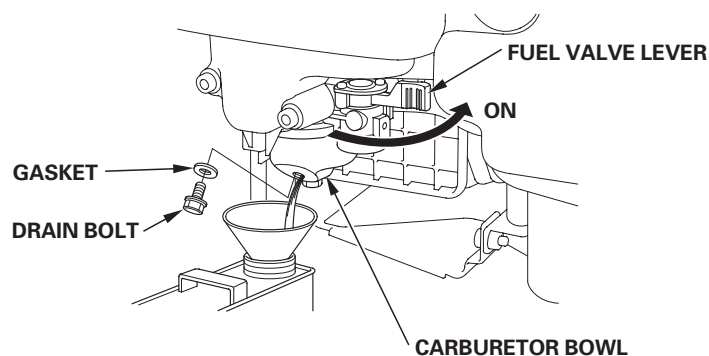

4. After draining the carburetor bowl and fuel tank, install the drain bolt and gasket and tighten securely.

### Engine Oil

1. Change the engine oil (see page 9).
2. Remove the spark plug (see page 10).
3. Pour a tablespoon 5 – 10 cm<sup>3</sup> (5 – 10 cc) of clean engine oil into the cylinder.
4. Pull the starter rope several times to distribute the oil in the cylinder.
5. Reinstall the spark plug.
6. Pull the starter rope slowly until resistance is felt. (At this time the index mark on the cooling fan aligns with the index mark on the fan cover). This will close the valves so moisture cannot enter the engine cylinder. Return the starter rope gently.

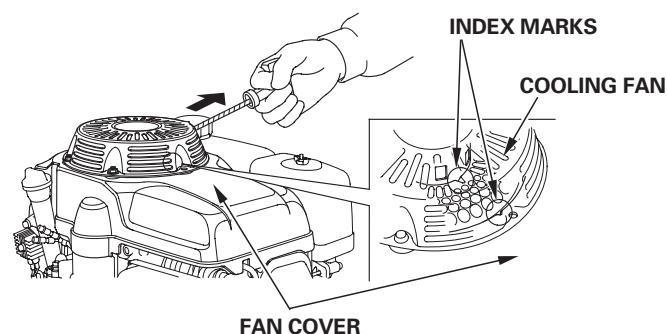

### Storage Precautions

If your engine will be stored with gasoline in the fuel tank and carburetor, it is important to reduce the hazard of gasoline vapor ignition. Select a well-ventilated storage area away from any appliance that operates with a flame, such as a furnace, water heater, or clothes dryer. Also avoid any area with a spark-producing electric motor, or where power tools are operated.

If possible, avoid storage areas with high humidity, because that promotes rust and corrosion.

Unless all fuel has been drained from the fuel tank, leave the fuel valve lever in the OFF position to reduce the possibility of fuel leakage.

Position the equipment so the engine is level. Tilting can cause fuel or oil leakage.

With the engine and exhaust system cool, cover the engine to keep out dust. A hot engine and exhaust system can ignite or melt some materials. Do not use sheet plastic as a dust cover. A nonporous cover will trap moisture around the engine, promoting rust and corrosion.

If equipped with a battery for electric starter types, recharge the battery once a month while the engine is in storage. This will help to extend the service life of the battery.



**Removal from Storage**

Check your engine as described in the *BEFORE OPERATION CHECKS* section of this manual (see page 3).

If the fuel was drained during storage preparation, fill the tank with fresh gasoline. If you keep a container of gasoline for refueling, be sure it contains only fresh gasoline. Gasoline oxidizes and deteriorates over time, causing hard starting.

If the cylinder was coated with oil during storage preparation, the engine will smoke briefly at startup. This is normal.

**TRANSPORTING**

If the engine has been running, allow it to cool for at least 15 minutes before loading the engine-powered equipment on the transport vehicle. A hot engine and exhaust system can burn you and can ignite some materials.

Keep the engine level when transporting to reduce the possibility of fuel leakage. Turn the fuel valve to the OFF position (see page 5).

**TAKING CARE OF UNEXPECTED PROBLEMS**

<b>ENGINE WILL NOT START</b>	<b>Possible Cause</b>	<b>Correction</b>
1. Electric starting (applicable types): Check battery and fuse.	Battery discharged.	Recharge battery.
	Fuse burnt out.	Replace fuse.
	Fuel valve OFF.	Move lever to ON position.
2. Check control positions.	Choke open.	Move control lever to CHOKE position unless the engine is warm.
	Engine switch OFF. (if equipped)	Turn engine switch to ON position or move the throttle control away from the OFF position.
	3. Check engine oil level.	Engine oil level low (Oil Alert types).
4. Check fuel.	Out of fuel.	Refuel (p. 8).
	Bad fuel; engine stored without treating or draining gasoline, or refueled with bad gasoline.	Drain fuel tank and carburetor (p.12). Refuel with fresh gasoline (p. 8).
5. Remove and inspect spark plug.	Spark plug faulty, fouled, or improperly gapped.	Gap or replace spark plug (p.10).
	Spark plug wet with fuel (flooded engine).	Dry and reinstall spark plug. Start engine with control lever in MAX. position.
6. Take engine to an authorized Honda servicing dealer, or refer to shop manual.	Fuel filter restricted, carburetor malfunction, ignition malfunction, valves stuck, etc.	Replace or repair faulty components as necessary.

<b>ENGINE LACKS POWER</b>	<b>Possible Cause</b>	<b>Correction</b>
1. Check air filter.	Filter element(s) restricted.	Clean or replace filter element(s) (p.10).
2. Check fuel.	Bad fuel; engine stored without treating or draining gasoline, or refueled with bad gasoline.	Drain fuel tank and carburetor (p.10). Refuel with fresh gasoline (p. 8).
3. Take engine to an authorized Honda servicing dealer, or refer to shop manual.	Fuel filter restricted, carburetor malfunction, ignition malfunction, valves stuck, etc.	Replace or repair faulty components as necessary.



## TECHNICAL & CONSUMER INFORMATION

### TECHNICAL INFORMATION

#### Serial Number Location

Record the engine serial number, type and purchase date in the space below. You will need this information when ordering parts and when making technical or warranty inquiries.

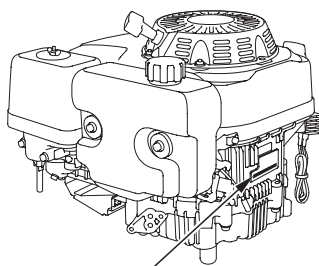

ENGINE SERIAL NUMBER & ENGINE TYPE LOCATION

Engine serial number: \_\_\_\_\_

Engine type: \_\_\_\_\_

Date Purchased: \_\_\_\_ / \_\_\_\_ / \_\_\_\_

#### Battery Connections for Electric Starter (applicable types)

Use a 12-volt battery with an ampere-hour rating of at least 18 Ah.

Be careful not to connect the battery in reverse polarity, as this will short circuit the battery charging system. Always connect the positive (+) battery cable to the battery terminal before connecting the negative (-) battery cable, so your tools cannot cause a short circuit if they touch a grounded part while tightening the positive (+) battery cable end.

### ⚠ WARNING

A battery can explode if you do not follow the correct procedure, seriously injuring anyone nearby.

Keep all sparks, open flames, and smoking materials away from the battery.

1. Connect the battery positive (+) cable to the starter solenoid terminal as shown.
2. Connect the battery negative (-) cable to an engine mounting bolt, frame bolt, or other good engine ground connection.
3. Connect the battery positive (+) cable to the battery positive (+) terminal as shown.
4. Connect the battery negative (-) cable to the battery negative (-) terminal as shown.
5. Coat the terminals and cable ends with grease.

NEGATIVE (-) BATTERY CABLE      POSITIVE (+) BATTERY CABLE

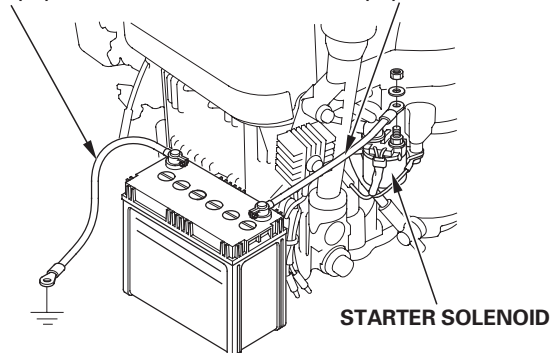

#### Remote Control Linkage

The control is provided with a hole for cable attachment. Install a solid wire cable as shown below. Do not use braided wire cable.

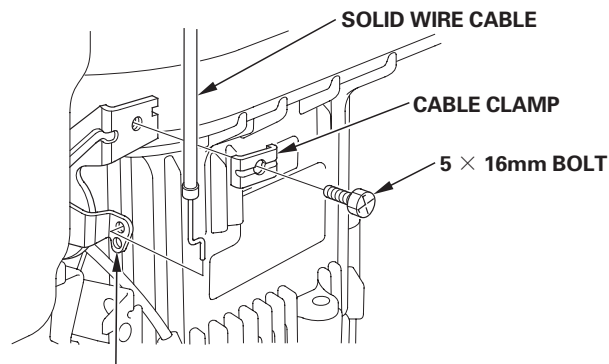

CONTROL LEVER

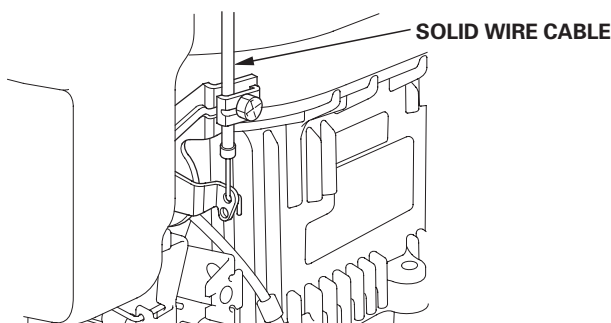

#### Carburetor Modifications for High Altitude Operation

At high altitude, the standard carburetor air-fuel mixture will be too rich. Performance will decrease, and fuel consumption will increase. A very rich mixture will also foul the spark plug and cause hard starting. Operation at an altitude that differs from that at which this engine was certified, for extended periods of time, may increase emissions.

High altitude performance can be improved by specific modifications to the carburetor. If you always operate your engine at altitudes above 1,500 meters (5,000 feet), have your servicing dealer perform this carburetor modification. This engine, when operated at high altitude with the carburetor modifications for high altitude use, will meet each emission standard throughout its useful life.

Even with carburetor modification, engine horsepower will decrease about 3.5% for each 300-meter (1,000-foot) increase in altitude. The effect of altitude on horsepower will be greater than this if no carburetor modification is made.

### NOTICE

*When the carburetor has been modified for high altitude operation, the air-fuel mixture will be too lean for low altitude use. Operation at altitudes below 1,500 meters (5,000 feet) with a modified carburetor may cause the engine to overheat and result in serious engine damage. For use at low altitudes, have your servicing dealer return the carburetor to original factory specifications.*



**Oxygenated Fuels**

Some conventional gasolines are being blended with alcohol or an ether compound. These gasolines are collectively referred to as oxygenated fuels. To meet clean air standards, some areas of the United States and Canada use oxygenated fuels to help reduce emissions.

If you use oxygenated fuel, be sure it is unleaded and meets the minimum octane rating requirements.

Before using an oxygenated fuel, try to confirm the fuel's contents. Some states/provinces require this information to be posted on the pump.

The following are the EPA approved percentages of oxygenates:

- ETHANOL** — (ethyl or grain alcohol) 10% by volume  
You may use gasoline containing up to 10% ethanol by volume. Gasoline containing ethanol may be marketed under the name Gasohol.
- MTBE** — (methyl tertiary butyl ether) 15% by volume  
You may use gasoline containing up to 15% MTBE by volume.
- METHANOL** — (methyl or wood alcohol) 5% by volume  
You may use gasoline containing up to 5% methanol by volume as long as it also contains cosolvents and corrosion inhibitors to protect the fuel system. Gasoline containing more than 5% methanol by volume may cause starting and/or performance problems. It may also damage metal, rubber, and plastic parts of your fuel system.

If you notice any undesirable operating symptoms, try another service station or switch to another brand of gasoline. Fuel system damage or performance problems resulting from the use of an oxygenated fuel containing more than the percentages of oxygenates mentioned above are not covered under the *Distributor's Limited Warranty*.

**Emission Control System Information****Source of Emissions**

The combustion process produces carbon monoxide, oxides of nitrogen, and hydrocarbons. Control of hydrocarbons and oxides of nitrogen is very important because, under certain conditions, they react to form photochemical smog when subjected to sunlight. Carbon monoxide does not react in the same way, but it is toxic.

Honda utilizes lean carburetor settings and other systems to reduce the emissions of carbon monoxide, oxides of nitrogen, and hydrocarbons.

**The U.S., California Clean Air Acts and Environment Canada**

EPA, California and Canadian regulations require all manufacturers to furnish written instructions describing the operation and maintenance of emission control systems.

The following instructions and procedures must be followed in order to keep the emissions from your Honda engine within the emission standards.

**Tampering and Altering**

Tampering with or altering the emission control system may increase emissions beyond the legal limit. Among those acts that constitute tampering are:

- Removal or alteration of any part of the intake, fuel, or exhaust systems.
- Altering or defeating the governor linkage or speed-adjusting mechanism to cause the engine to operate outside its design parameters.

**Problems That May Affect Emissions**

If you are aware of any of the following symptoms, have your engine inspected and repaired by your servicing dealer.

- Hard starting or stalling after starting.
- Rough idle.
- Misfiring or backfiring under load.
- Afterburning (backfiring).
- Black exhaust smoke or high fuel consumption.

**Replacement Parts**

The emission control systems on your Honda engine were designed, built, and certified to conform with EPA, California and Canadian emission regulations. We recommend the use of genuine Honda parts whenever you have maintenance done. These original-design replacement parts are manufactured to the same standards as the original parts, so you can be confident of their performance. The use of replacement parts that are not of the original design and quality may impair the effectiveness of your emission control system.

A manufacturer of an aftermarket part assumes the responsibility that the part will not adversely affect emission performance. The manufacturer or rebuilder of the part must certify that use of the part will not result in a failure of the engine to comply with emission regulations.

**Maintenance**

Follow the maintenance schedule on page 7. Remember that this schedule is based on the assumption that your machine will be used for its designed purpose. Sustained high-load or high-temperature operation, or use in unusually wet or dusty conditions, will require more frequent service.





**Air Index**

An Air Index Information hang tag/label is applied to engines certified to an emission durability time period in accordance with the requirements of the California Air Resources Board.

The bar graph is intended to provide you, our customer, the ability to compare the emissions performance of available engines. The lower the Air Index, the less pollution.

The durability description is intended to provide you with information relating the engine's emission durability period. The descriptive term indicates the useful life period for the engine's emission control system. See your *Emission Control System Warranty* for additional information.

Descriptive Term	Applicable to Emissions Durability Period
Moderate	50 hours [0–65 cm <sup>3</sup> (0–65 cc)] 125 hours [greater than 65 cm <sup>3</sup> (65 cc)]
Intermediate	125 hours [0–65 cm <sup>3</sup> (0–65 cc)] 250 hours [greater than 65 cm <sup>3</sup> (65 cc)]
Extended	300 hours [0–65 cm <sup>3</sup> (0–65 cc)] 500 hours [greater than 65 cm <sup>3</sup> (65 cc)]

The Air Index Information hang tag/label must remain on the engine until it is sold. Remove the hang tag before operating the engine.

**Specifications****GXV340**

Length × Width × Height	433 × 382 × 406 mm (17.0 × 15.0 × 16.0 in)
Dry weight	31 kg (68 lbs)
Engine type	4-stroke, overhead valve, single cylinder
Displacement [Bore × Stroke]	338 cm <sup>3</sup> (20.6 cu-in) [82 × 64 mm (3.2 × 2.5 in)]
Max. output	6.6 kW (9.0 PS, 8.9 bhp) at 3,600 rpm
Max. torque	21.6 N·m (2.20 kgf·m, 15.9 lbf·ft) at 2,500 rpm
Engine oil capacity	1.10 ℓ (1.16 US qt, 0.97 Imp qt)
Fuel tank capacity	2.1 ℓ
Fuel consumption	2.3 ℓ/h at 3,000 rpm
Cooling system	Forced air
Ignition system	Transistorized magneto
PTO shaft rotation	Counterclockwise

**GXV390**

Length × Width × Height	433 × 382 × 406 mm (17.0 × 15.0 × 16.0 in)
Dry weight	32 kg (71 lbs)
Engine type	4-stroke, overhead valve, single cylinder
Displacement [Bore × Stroke]	389 cm <sup>3</sup> (23.7 cu-in) [88 × 64 mm (3.5 × 2.5 in)]
Max. output	7.6 kW (10.3 PS, 10.2 bhp) at 3,600 rpm
Max. torque	24.2 N·m (2.47 kgf·m, 17.8 lbf·ft) at 2,500 rpm
Engine oil capacity	1.10 ℓ (1.16 US qt, 0.97 Imp qt)
Fuel tank capacity	2.1 ℓ
Fuel consumption	2.5 ℓ/h at 3,000 rpm
Cooling system	Forced air
Ignition system	Transistorized magneto
PTO shaft rotation	Counterclockwise

**Tuneup Specifications**

ITEM	SPECIFICATION	MAINTENANCE
Spark plug gap	0.70–0.80 mm (0.028–0.031 in)	Refer to page: 10
Idle speed	1,400 ± 150 rpm	See your authorized Honda dealer
Valve clearance (cold)	IN: 0.15 ± 0.02 mm EX: 0.20 ± 0.02 mm	
Other specifications	No other adjustments needed.	







**Quick Reference Information**

Fuel	Unleaded gasoline (Refer to page 8)	
	U.S.	Pump octane rating 86 or higher
	Except U.S.	Research octane rating 91 or higher
Engine oil	SAE 10W-30, API SJ or SL, for general use. Refer to page 8.	
Spark plug	BPR5ES (NGK) W16EPR-U (DENSO)	
Maintenance	Before each use:	
	<ul style="list-style-type: none"> <li>• Check engine oil level. Refer to page 9.</li> <li>• Check air filter. Refer to page 10.</li> </ul>	
	First 20 hours: Change engine oil. Refer to page 9. Subsequent: Refer to the maintenance schedule on page 7.	

**Wiring Diagrams**

**BASIC CIRCUIT**

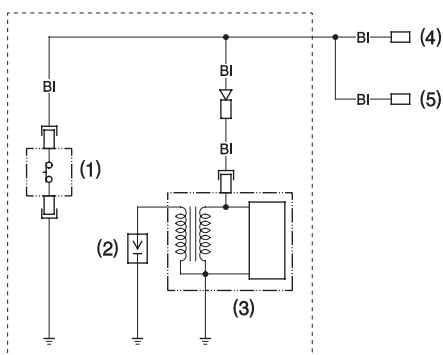

**OIL ALERT CIRCUIT**

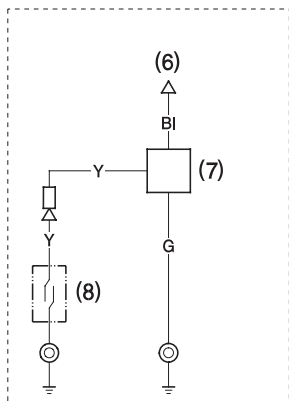

**12V STARTER CIRCUIT**

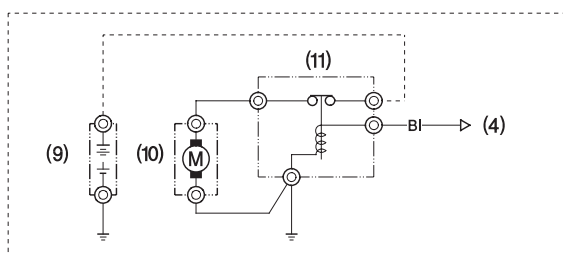

**1A CHARGING SYSTEM**

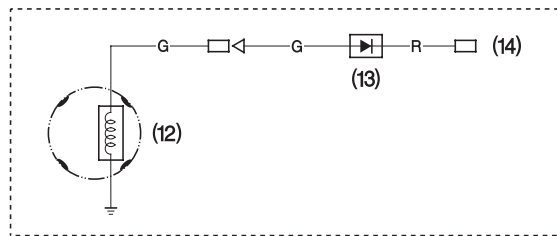

**3A CHARGING SYSTEM**

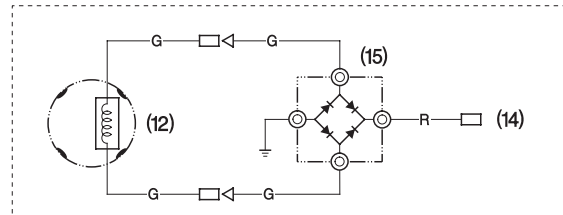

**10A CHARGING SYSTEM**

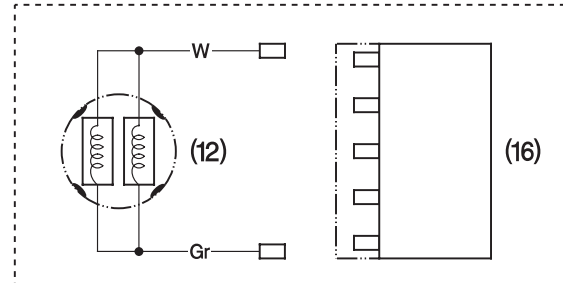

- |                           |                       |
|---------------------------|-----------------------|
| (1) ENGINE STOP SWITCH    | (9) BATTERY (12 V)    |
| (2) SPARK PLUG            | (10) STARTER MOTOR    |
| (3) IGNITION COIL         | (11) STARTER SOLENOID |
| (4) TO ENGINE SWITCH      | (12) CHARGING COIL    |
| (5) TO OIL ALERT CIRCUIT  | (13) DIODE            |
| (6) TO ENGINE STOP SWITCH | (14) TO LOAD          |
| (7) OIL ALERT BUZZER      | (15) RECTIFIER        |
| (8) OIL LEVEL SWITCH      | (16) REGULATOR        |

Bl	Black	Br	Brown
Y	Yellow	O	Orange
Bu	Blue	Lb	Light blue
G	Green	Lg	Light green
R	Red	P	Pink
W	White	Gr	Gray



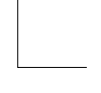

**CONSUMER INFORMATION**

**Distributor/Dealer Locator Information**

**United States, Puerto Rico, and U.S. Virgin Islands:**

Call (800) 426-7701  
or visit our website: [www.honda-engines.com](http://www.honda-engines.com)

**Canada:**

Call (888) 9HONDA9  
or visit our website: [www.honda.ca](http://www.honda.ca)

**For European Area:**

visit our website: <http://www.honda-engines-eu.com>

**Customer Service Information**

Serviceing dealership personnel are trained professionals. They should be able to answer any question you may have. If you encounter a problem that your dealer does not solve to your satisfaction, please discuss it with the dealership's management. The Service Manager, General Manager, or Owner can help. Almost all problems are solved in this way.

**United States, Puerto Rico, and U.S. Virgin Islands:**

If you are dissatisfied with the decision made by the dealership's management, contact the Honda Regional Engine Distributor for your area.

If you are still dissatisfied after speaking with the Regional Engine Distributor, you may contact the Honda Office as shown.

**All Other Areas:**

If you are dissatisfied with the decision made by the dealership's management, contact the Honda Office as shown.

«**Honda's Office**»

When you write or call, please provide this information:

- Equipment manufacturer's name and model number that the engine is mounted on
- Engine model, serial number, and type (see page 14 )
- Name of dealer who sold the engine to you
- Name, address, and contact person of the dealer who services your engine
- Date of purchase
- Your name, address and telephone number
- A detailed description of the problem

**United States, Puerto Rico, and U.S. Virgin Islands:**

**American Honda Motor Co., Inc.**

Power Equipment Division  
Customer Relations Office  
4900 Marconi Drive  
Alpharetta, GA 30005-8847

Or telephone: (770) 497-6400, 8:30 am - 8:00 pm EST

**Canada:**

**Honda Canada, Inc.**

715 Milner Avenue  
Toronto, ON  
M1B 2K8

Telephone: (888) 9HONDA9	Toll free
(888) 946-6329	
English: (416) 299-3400	Local Toronto dialing area
French: (416) 287-4776	Local Toronto dialing area
Facsimile: (877) 939-0909	Toll free
(416) 287-4776	Local Toronto dialing area

**Australia:**

**Honda Australia Motorcycle and Power Equipment Pty. Ltd.**

1954 – 1956 Hume Highway Campbellfield Victoria 3061

Telephone: (03) 9270 1111  
Facsimile: (03) 9270 1133

**For European Area:**

**Honda Europe NV.**

European Engine Center

<http://www.honda-engines-eu.com>

**All Other Areas:**

Please contact the Honda distributor in your area for assistance.



**HONDA**  
The Power of Dreams



# Proof of maintenance



**Warranty claim for this machine only apply for performance of the mandatory maintenance works (by an authorised specialist workshop)! After each completed performance of a maintenance interval the included form must be fill out, stamped, signed and send back to us immediately. <sup>1)</sup>**

<sup>1)</sup> via e-mail to [service@probst-handling.de](mailto:service@probst-handling.de) / via fax or post

Operator: \_\_\_\_\_  
 Device type: \_\_\_\_\_ Article -No.: \_\_\_\_\_  
 Device-No.: \_\_\_\_\_ Year of make: \_\_\_\_\_

First inspection after 25 operating hours		
Date:	Maintenance work:	Inspection by company:
		Company Stamp
		.....
		Name / Signature

All 50 operating hours		
Date:	Maintenance work:	Inspection by company:
		Company Stamp
		.....
		Name / Signature
		Inspection by company:
		Company Stamp
		.....
		Name / Signature
		Inspection by company:
		Company Stamp
		.....
		Name / Signature

Minimum 1x per year		
Date:	Maintenance work:	Inspection by company:
		Company Stamp
		.....
		Name / Signature
		Inspection by company:
		Company Stamp
		.....
		Name / Signature

8 7 6 5 4 3 2 1

F

E

D

C

B

A

F

E

D

C

B

A

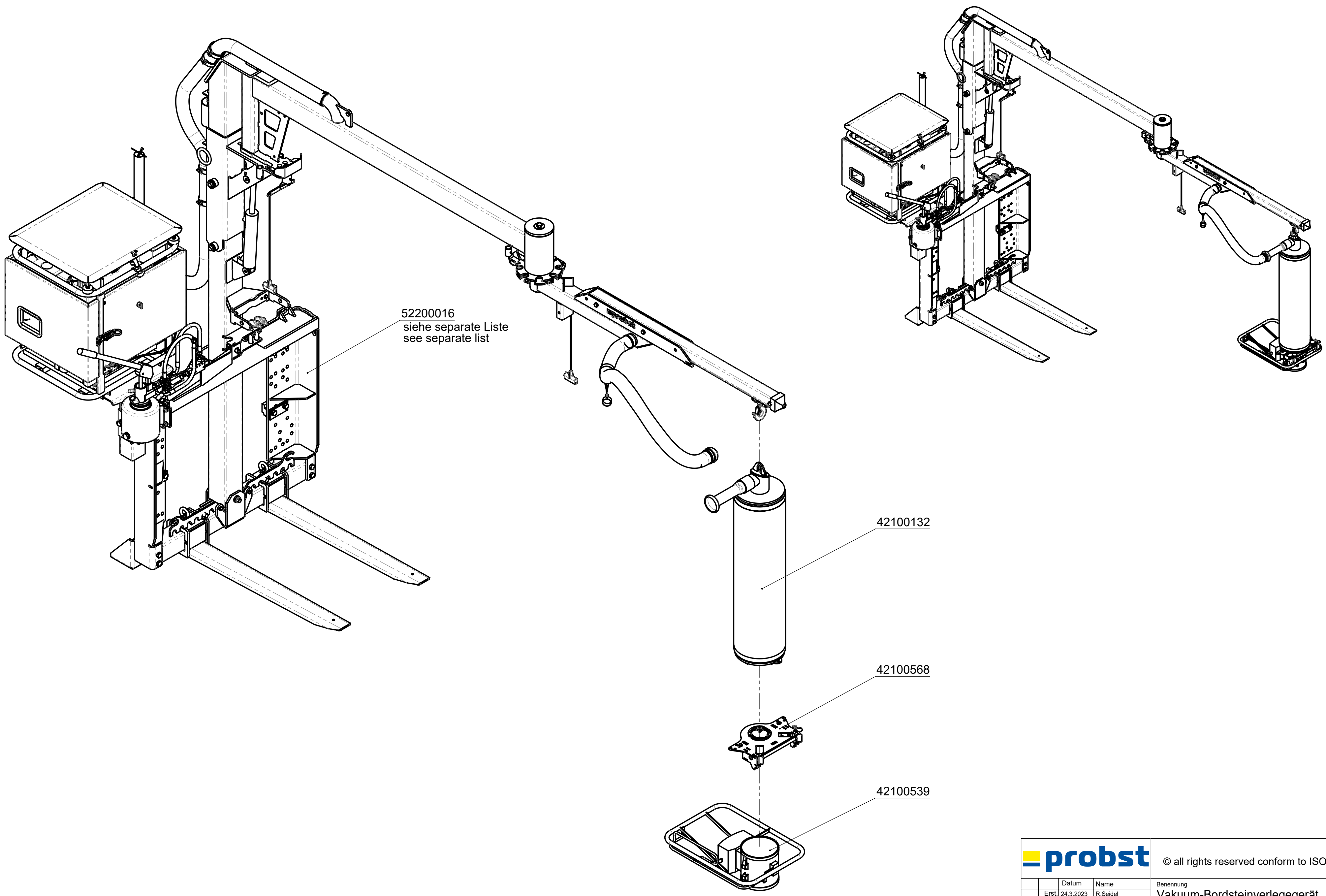

52200016  
siehe separate Liste  
see separate list

42100132

42100568

42100539

		© all rights reserved conform to ISO 16016	
	Datum	Name	Benennung
	Erst. 24.3.2023	R.Seidel	Vakuum-Bordsteinverlegegerät
	Gepr. 25.4.2023	R.Northe	JUMBO-BV-VARIO-150-B
			Artikelnummer/Zeichnungsnummer
			E52200016-150
Zust.	Urspr.	Ers. f.	Ers. d.
			Blatt 1 von 1

8 7 6 5 4 3 2 1

8 7 6 5 4 3 2 1

F

E

D

C

B

A

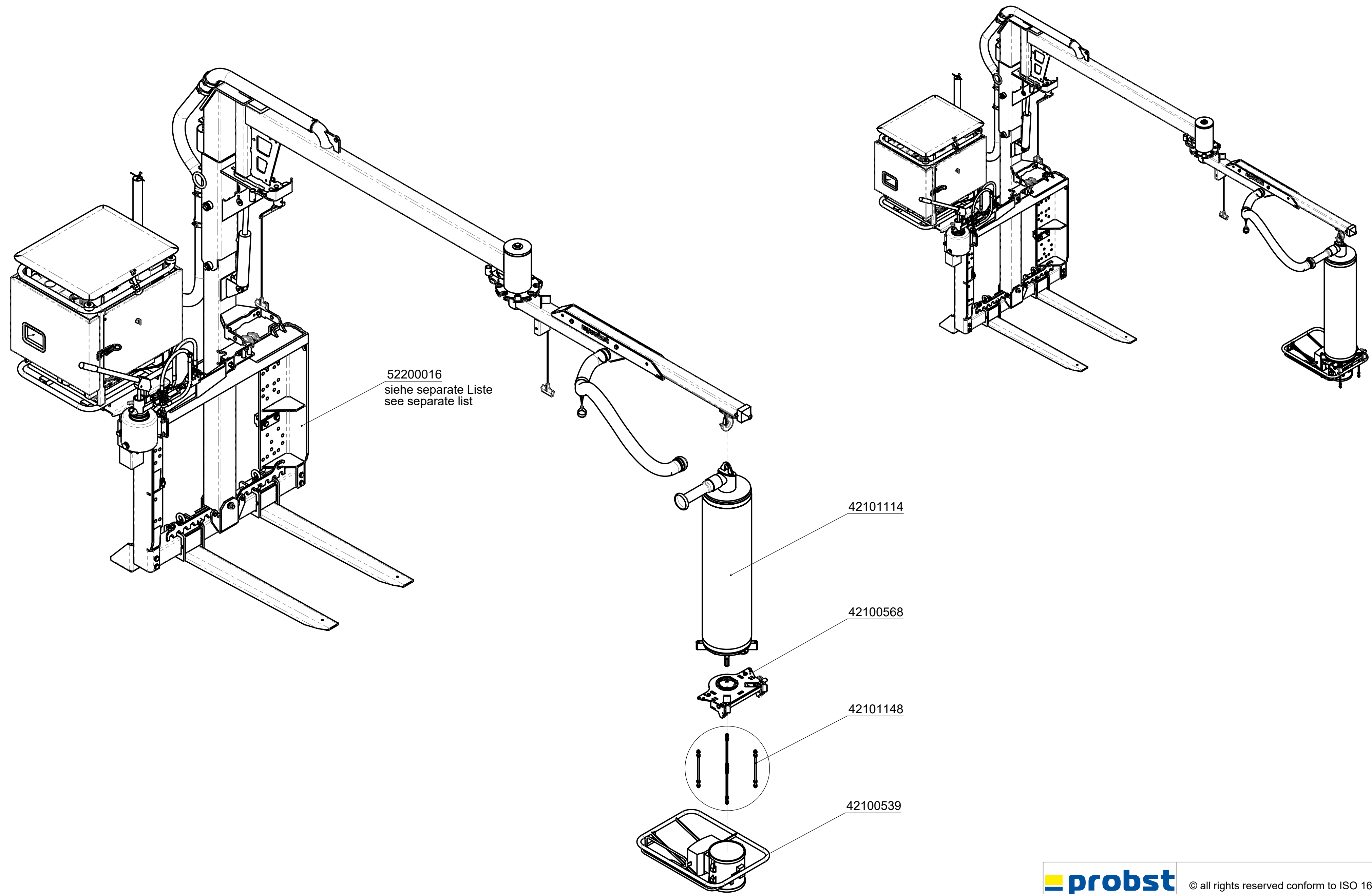

52200016  
siehe separate Liste  
see separate list

42101114

42100568

42101148

42100539

			© all rights reserved conform to ISO 16016	
	Datum	Name	Benennung	
	Erst. 24.3.2023	R.Seidel	Vakuum-Bordsteinverlegegerät	
	Gepr. 25.4.2023	R.Northe	JUMBO-BV-VARIO-200-B	
			Artikelnummer/Zeichnungsnummer	Blatt
			E52200016-200	1
				von 1
Zust.	Urspr.	Ers. f.	Ers. d.	

8 7 6 5 4 3 2 1



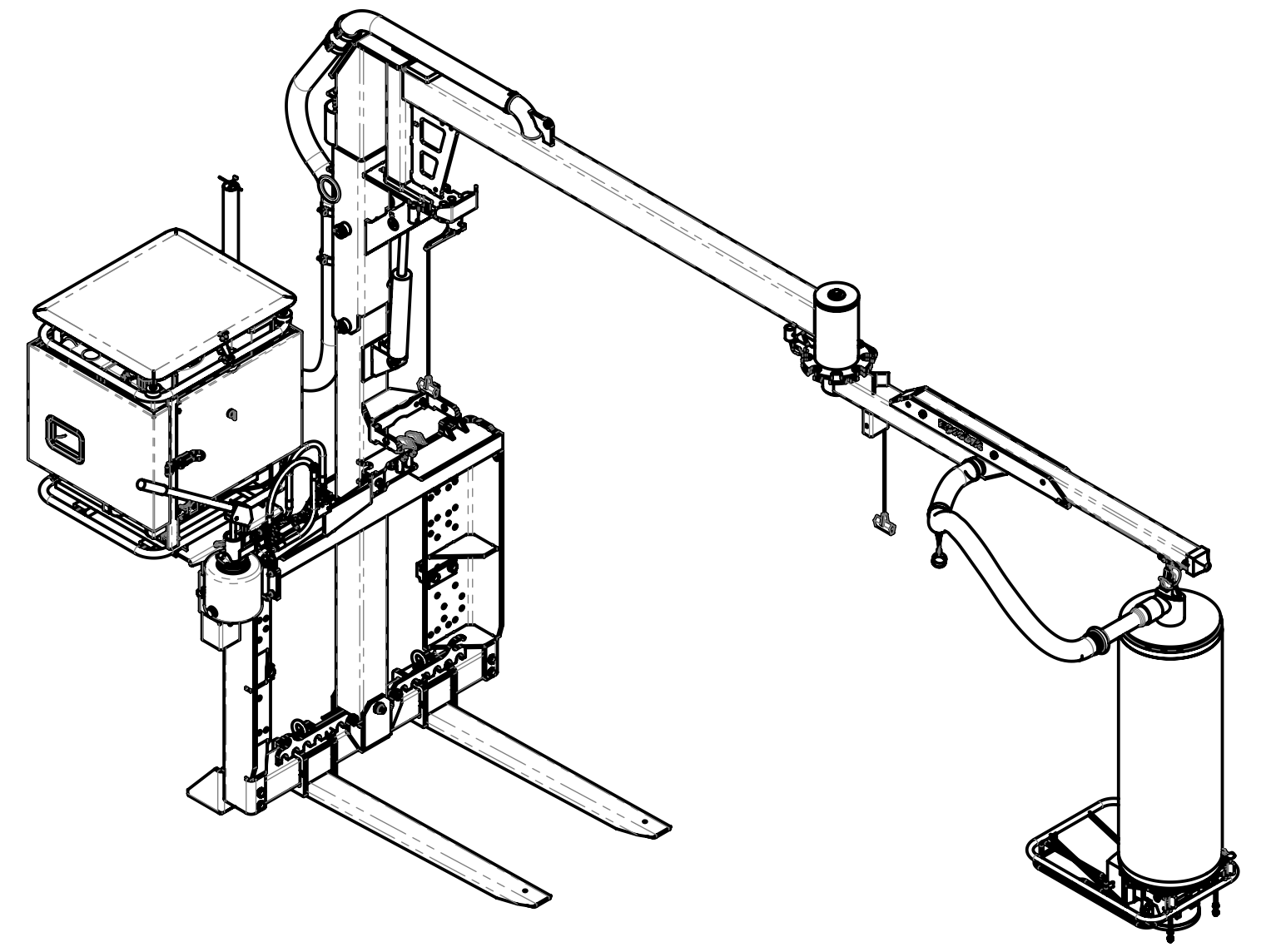
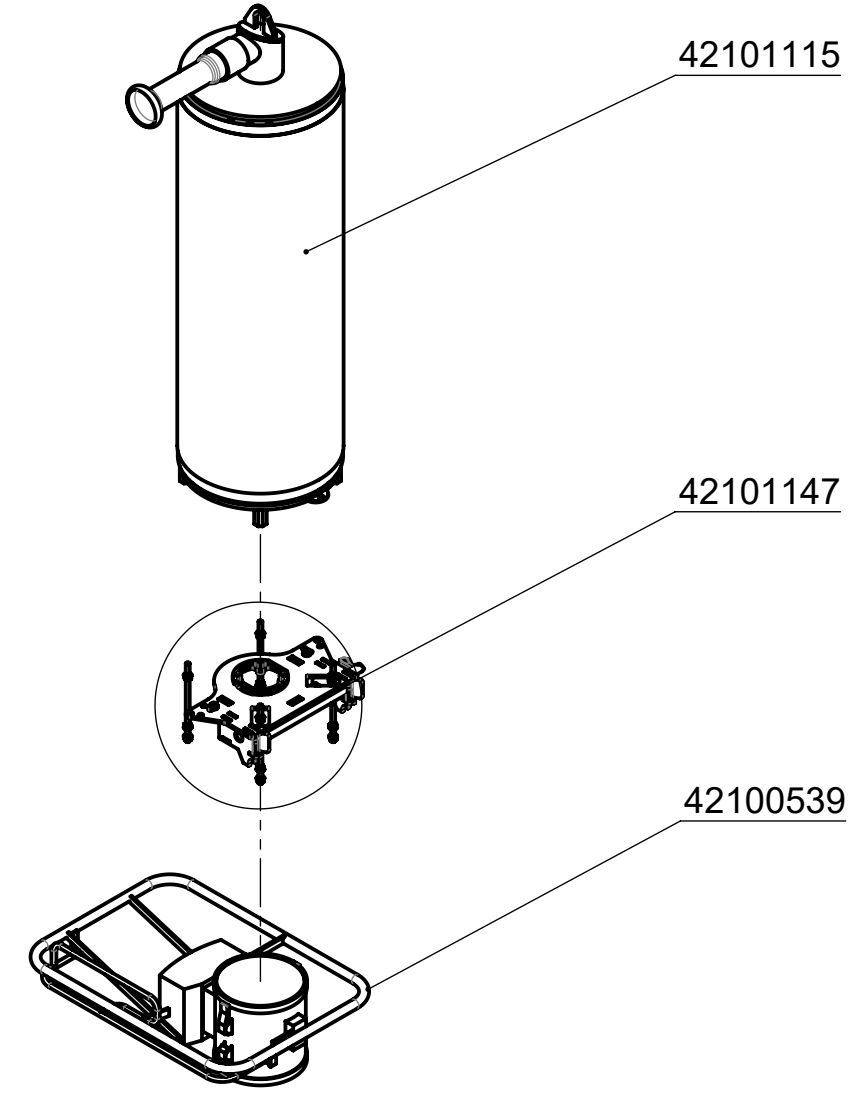
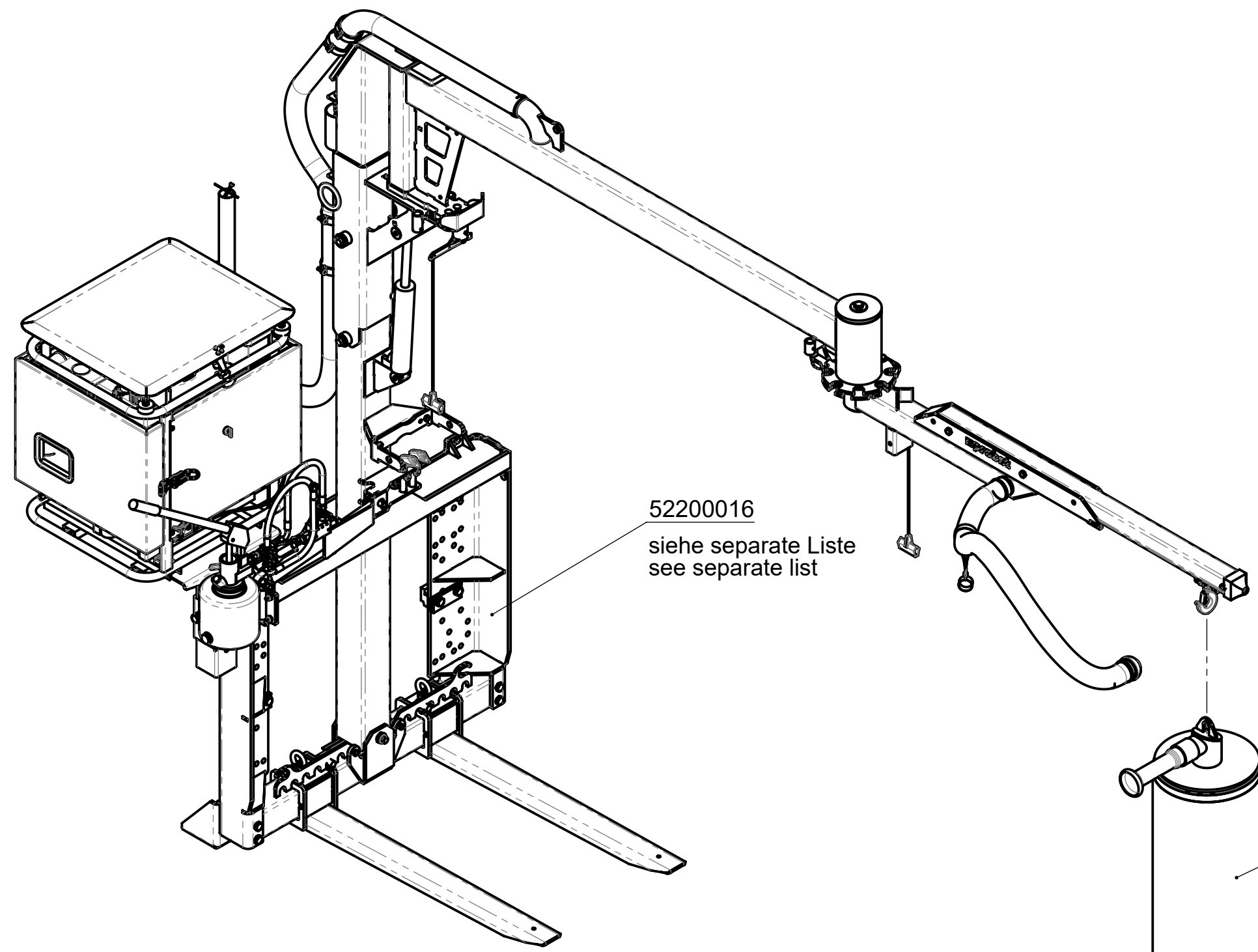

Für Maße, ohne Toleranzangaben gelten folgende Normen		Spanen + Biegen	Schweißkonstruktionen	Thermisches Schneiden
Längen, Winkelmaße, Rundungshalbmesser & Fasenhöhe		DIN EN ISO 2768-m	DIN EN ISO 13920-A	t ≤ 20 mm DIN EN ISO 9013-341
Geradheit / Ebenheit, sowie Form und Lage		DIN EN ISO 2768-K	DIN EN ISO 13920-E	t > 20 mm DIN EN ISO 9013-342
Maße DIN EN ISO 14405		Keine Änderungen ohne Rücksprache mit TB!		
Oberflächen nach DIN EN ISO 1302		allgemeiner Biegehalbmesser = Blechstärke		
Fehlende Maße sind dem 3D-Modell zu entnehmen. Fertigteil ist Maßgebend				
Das Dokument ist Freigegeben		© all rights reserved conform to ISO 16016		
Oberflächenbehandlung		Gewicht: 604,66 kg		Werkstoff:
Farbe:		Benennung <b>Vakuum-Bordsteinverlegegerät JUMBO-BV-VARIO-250-B</b>		
Datum		Name		Artikelnummer/Zeichnungsnummer
Erst. 27.3.2023		R.Seidel		
Gepr. 25.4.2023		R.Northe		Blatt 1 von 1
Zust.	Änderungstext	Datum	von	Urspr.
E52200016-250				Maßstab 1:15
				Blattformat A2



8

7

6

5

4

3

2

1

42200369  
siehe separate Liste  
see separate list

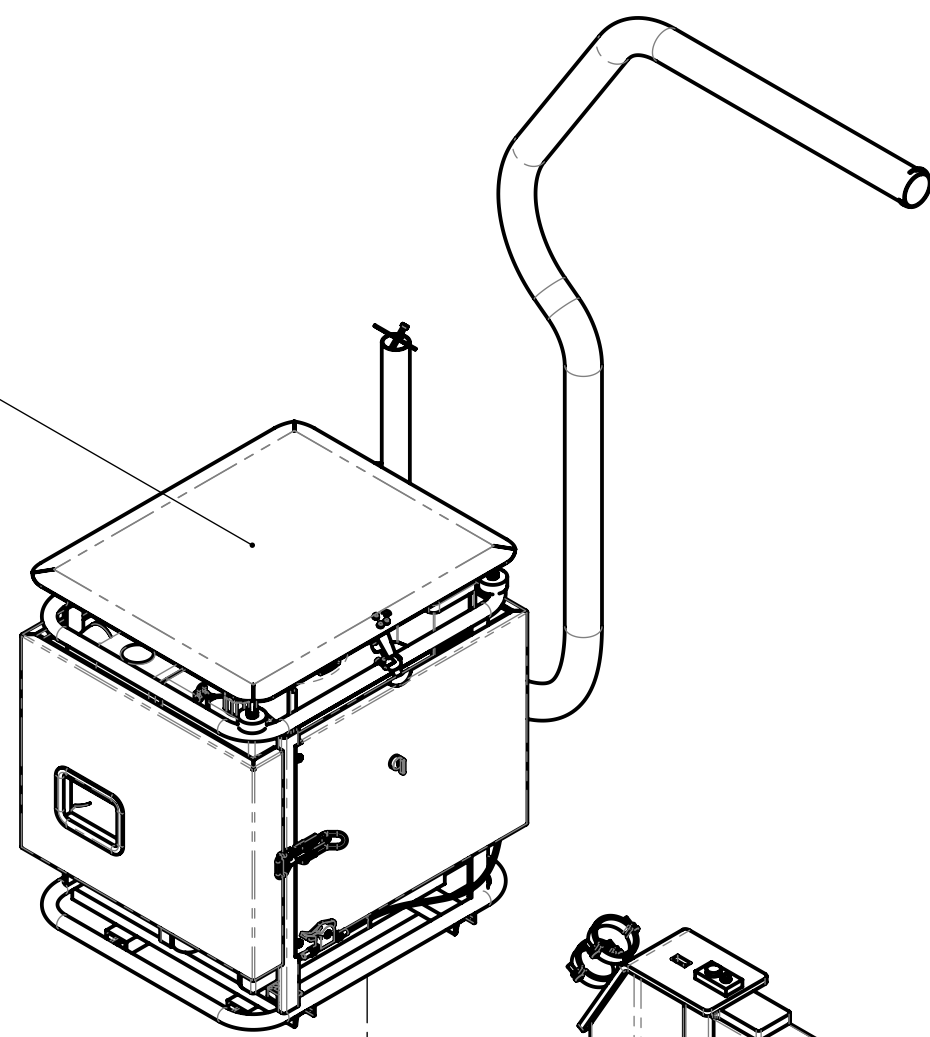

42200475  
siehe separate Liste  
see separate list

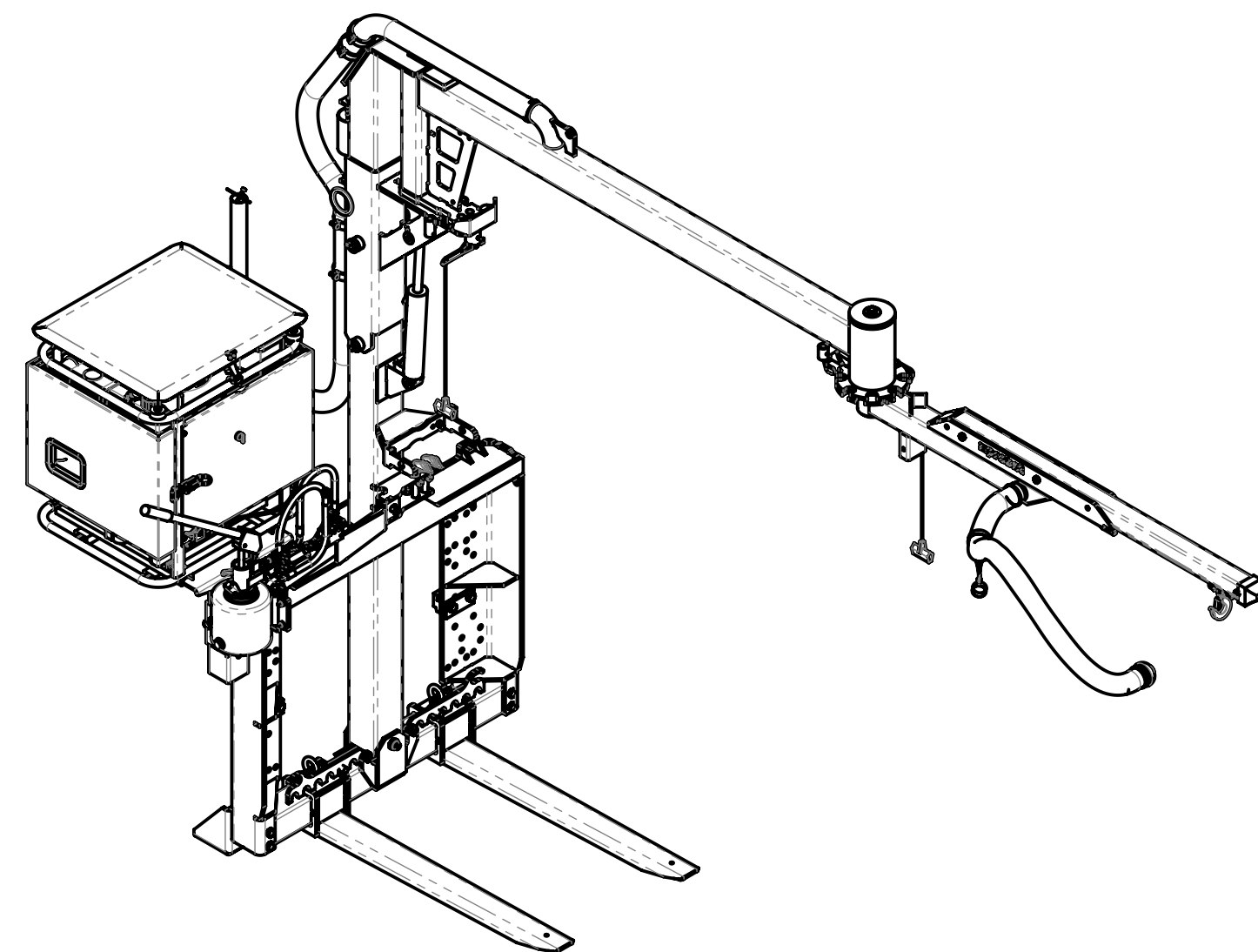
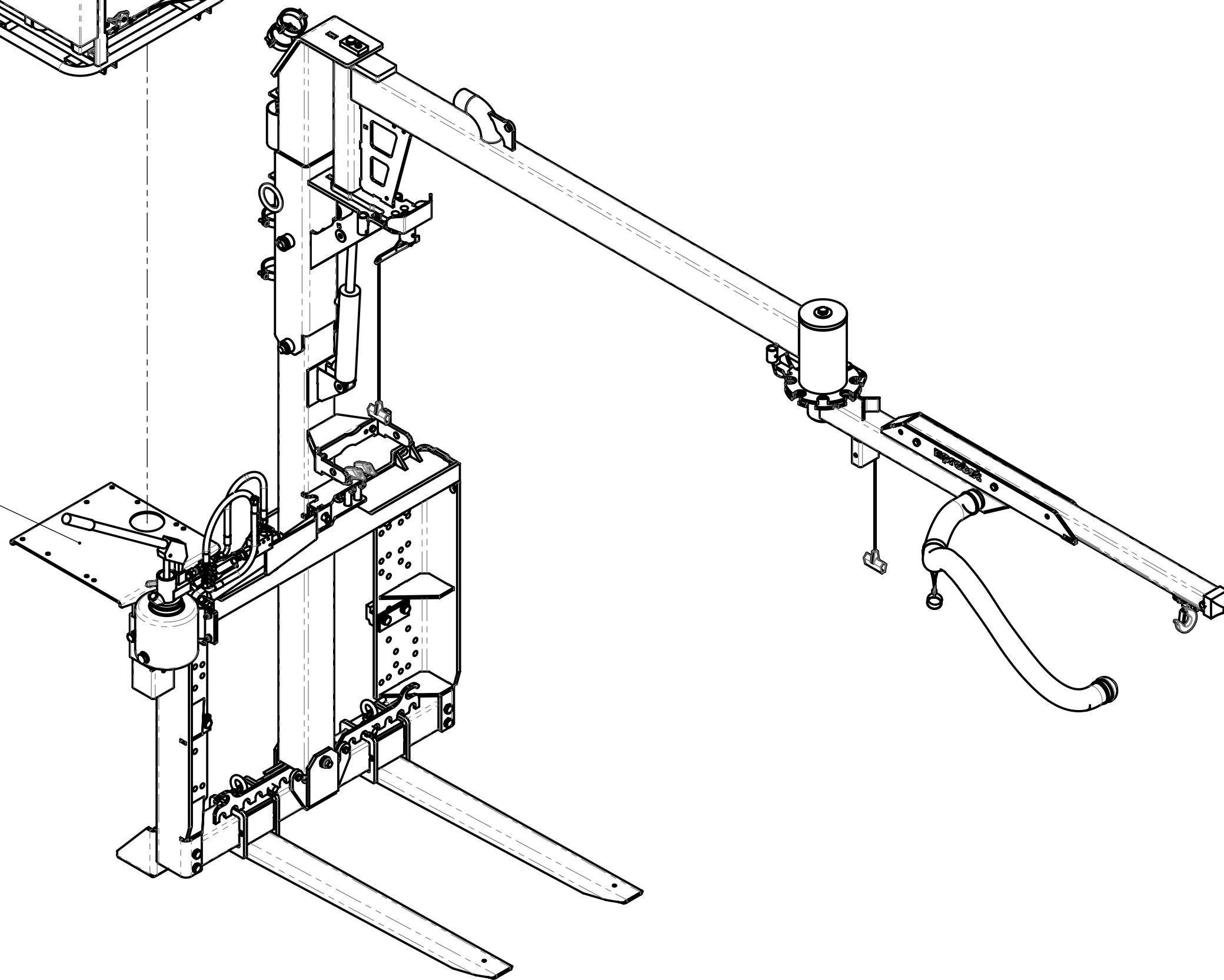

© all rights reserved conform to ISO 16016

Datum	Name
Erst. 24.3.2023	R.Seidel
Gepr. 25.4.2023	R.Northe

Benennung  
Grundgerät JUMBO-BV-VARIO-B

1	Zust.	Urspr.
---	-------	--------

Artikelnummer/Zeichnungsnummer  
E52200016

Blatt  
1  
von 1

Ers. f.                      Ers. d.

8

7

6

5

4

3

2

1

8 7 6 5 4 3 2 1

F

E

D

C

B

A

F

E

D

C

B

A

42200434

25050016

33506170

21050017

21050017

42200434

21050017

42200276  
siehe separate Liste  
see separate list

21050017

20190010

20480046

20000018

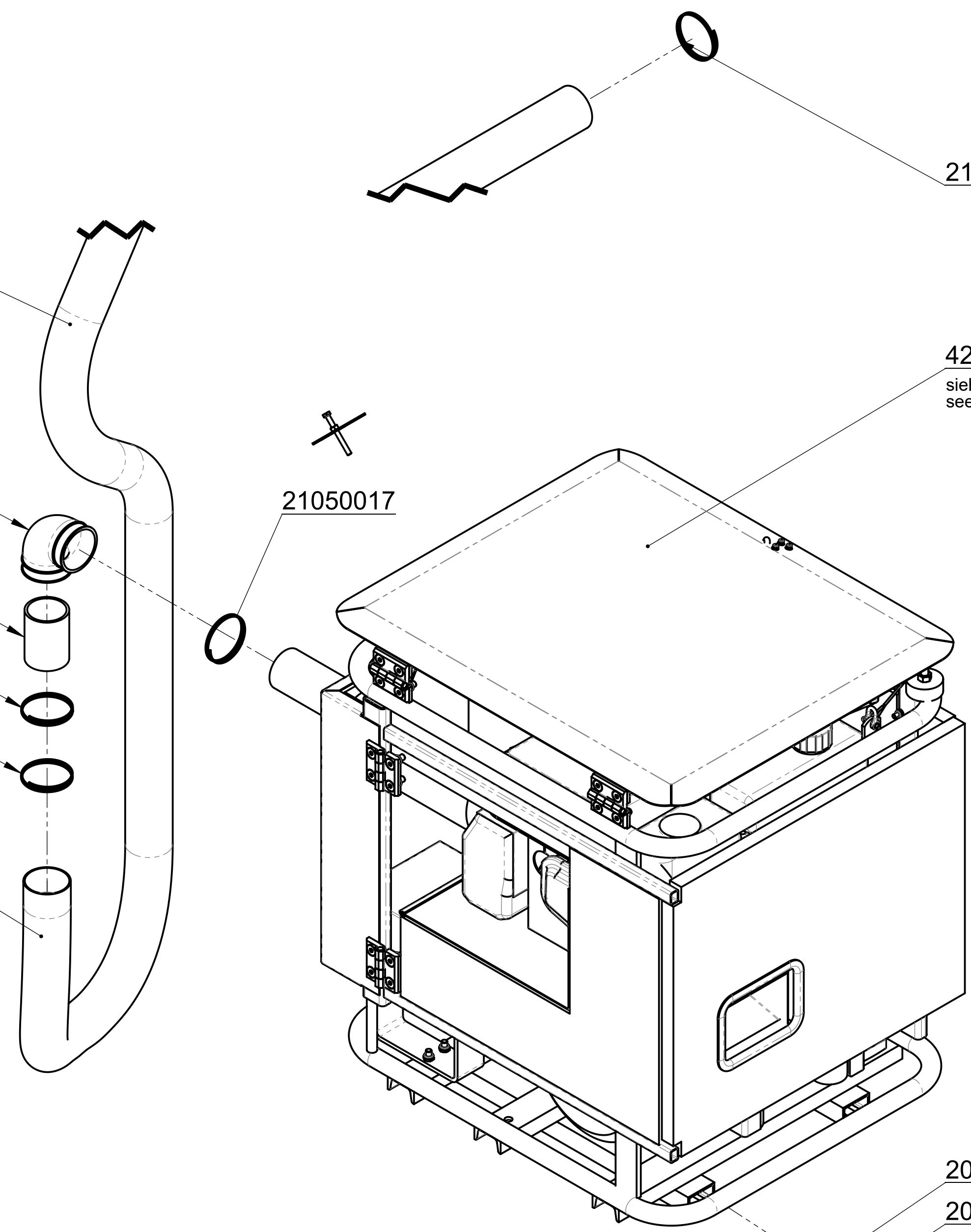
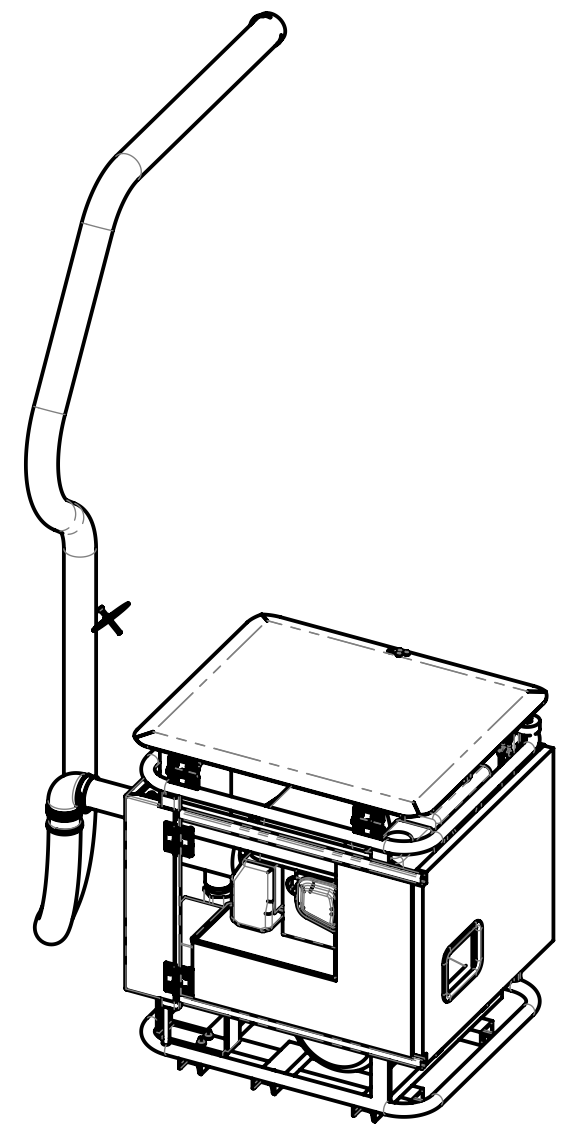

		© all rights reserved conform to ISO 16016	
	Datum	Name	Benennung
	Erst. 24.1.2014	Ralf.Northe	Vakuum-Gebläseeinheit kpl.
	Gepr. 16.11.2020	M.Wunder	mit Anbauteilen für Jumbo BV-b
			mit E-Start, VGE-3RGb-E und Gehäuse Gebläse BV
			Artikelnummer/Zeichnungsnummer
2			E42200369
1			Blatt 1
Zust.	Urspr.	Ers. f.	Ers. d.
			von 1

8 7 6 5 4 3 2 1







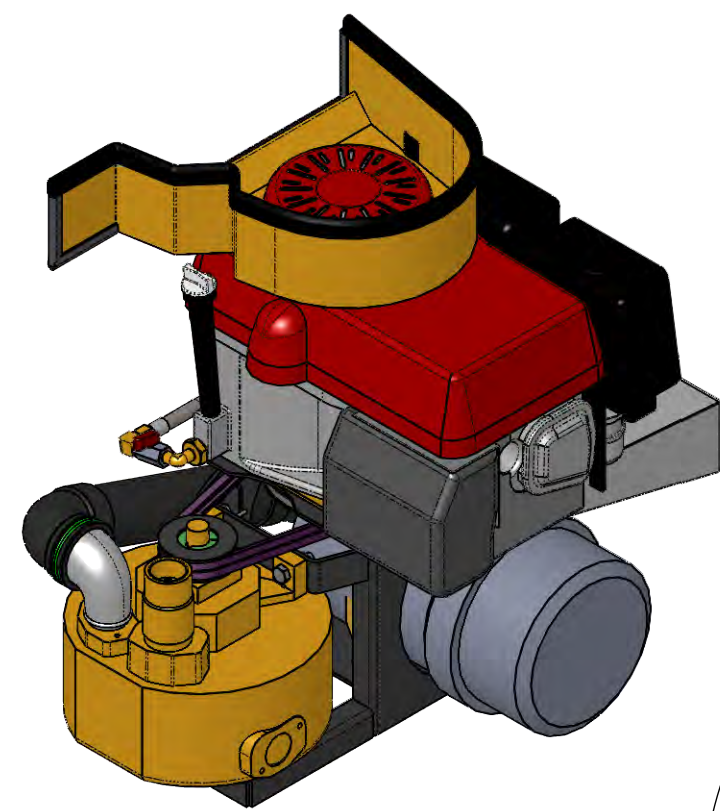

Detail X

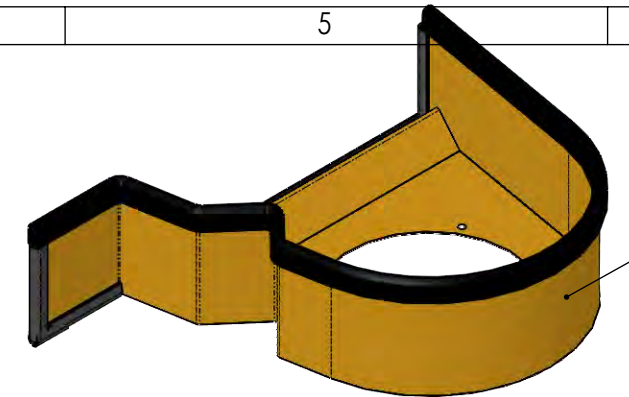
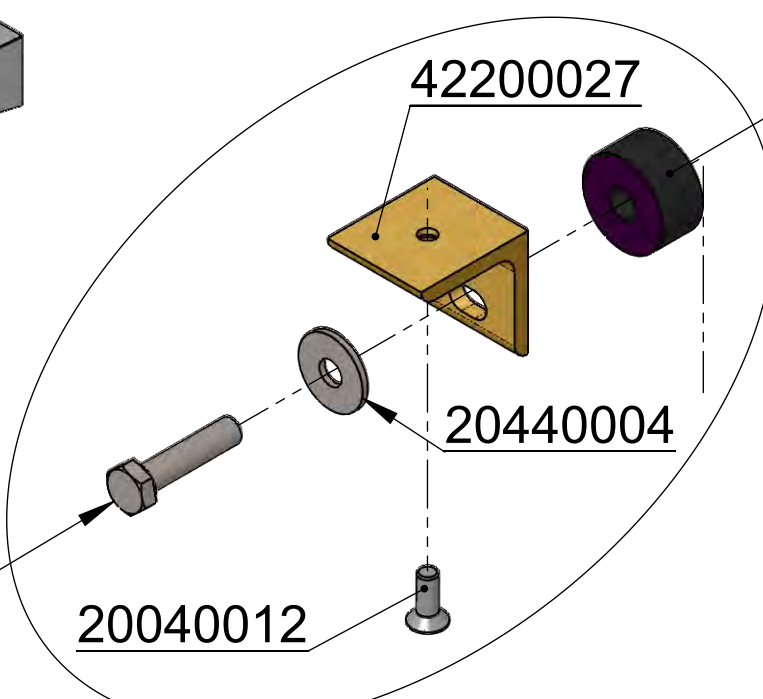

42200311

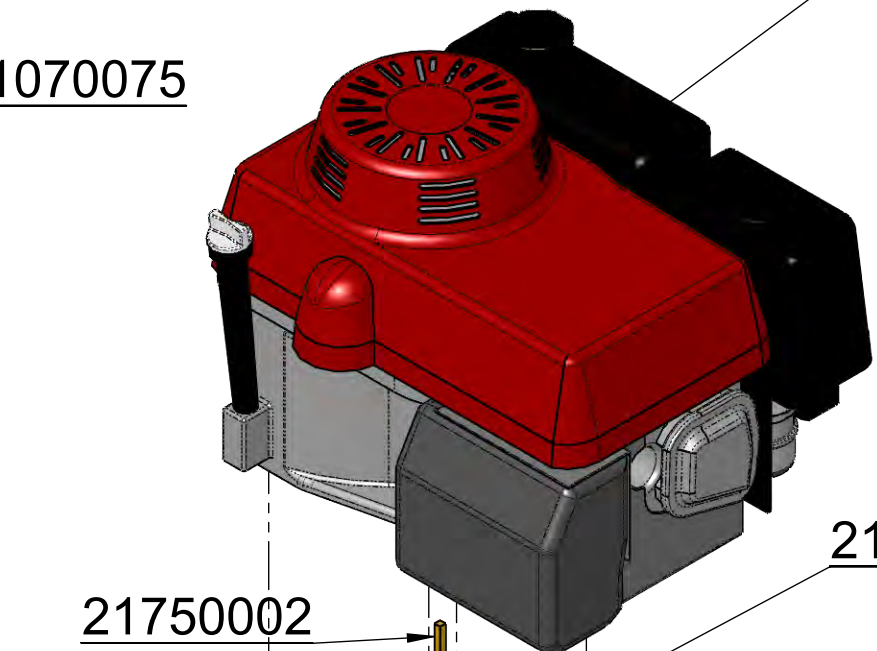

26100042

complete with insert  
42100085 Filter-Patrone  
Filter insert

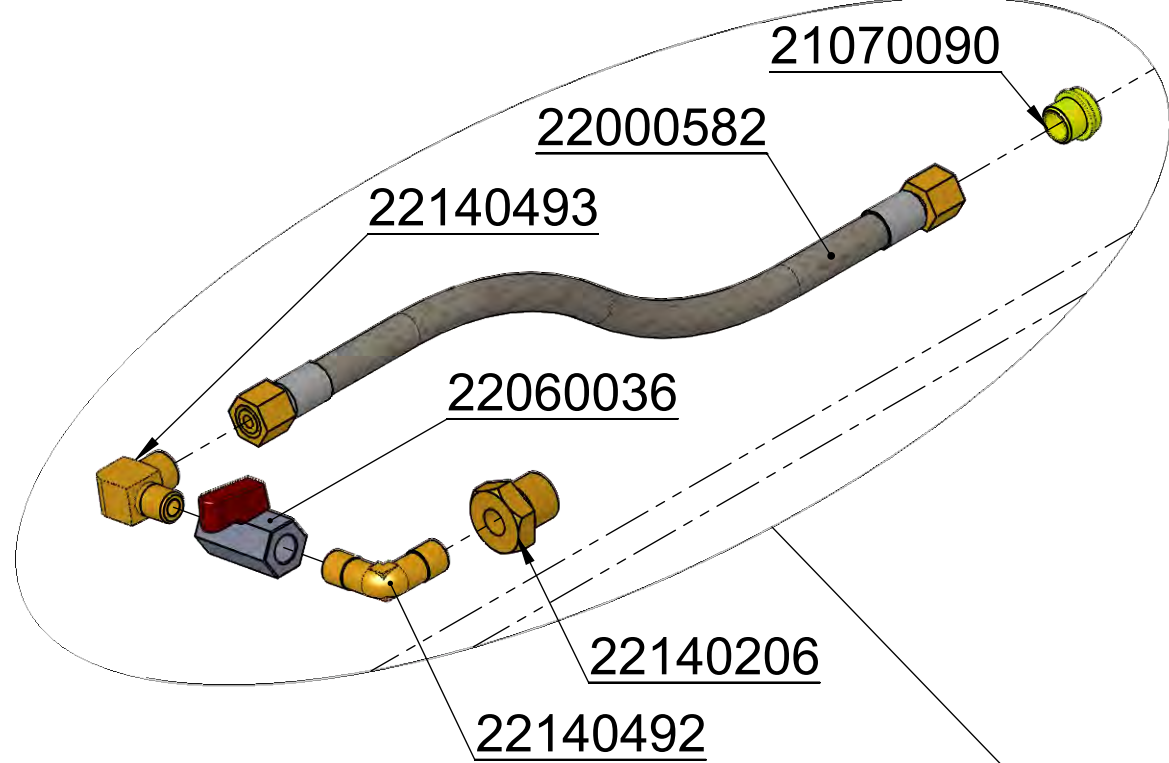

21070090

22000582

22140493

22060036

22140206

22140492

21750002

21110003

21410002

21100008

21110002

21410001

20100015

20000021

20100015

42200470

20100005

42200029

42200028

20020138

20100017

42200277

21050004

27150002

27010025

20100022

42200032

20000026

20530047

20100015

20000014

42200441

20440004

20000046

21070001

25000008

20100015

Pos.	Stk.	Artikel Nr.	V.	Beschreibung	Länge	Gewicht	Material
1	1	42200032	5	Schweißteil Motorkonsole		8,08 kg	
2	1	42200029	1	Schlitten Motorkonsole zu Jumbo BV		2,09 kg	S235JRG2
3	1	42200441	0	Seitenkanalverdichter rechts- drehend mit Stiftbohrungen		70,15 kg	
4	1	26100042	0	Benzinmotor Honda GXV390T1-DN-E5-OH mit E-Start		32,54 kg	
5	1	21410001	0	Taperlock-Buchse 1210		0,2 kg	
6	1	21110002	0	Keilriemenscheibe SPZ 80x2 für Taperbuchse		0,59 kg	Stahl
7	1	21410002	0	Taperlock-Buchse 2012, Dm 25,4, für Paßfeder 6,3		0,5 kg	
8	1	21110003	0	Keilriemenscheibe SPZ-180x2 für Taperbuchse		2,3 kg	Stahl
9	1	21750002	0	Paßfeder, 6,35x6,35x43 H9 C45K			Stahl
10	2	21100008	0	Keilriemen AVX 10x865		0,1 kg	Gummi
11	1	42200027	0	Winkel für Motorkonsole zu BV	35.0	0,10 kg	S235JRG2
12	1	20040012	0	Senkschraube DIN7991 M6x16		0,0 kg	
13	1	25000008	0	Luffilter Euro-Piclon für Jumbo BV		1,9 kg	
14	1	42200311	0	Zuluftrichter kompl.-GXV-340		1,49 kg	
15	1	27010025	0	Doppel-Gewinde-Nippel 1/4 x 40, verz.		0,1 kg	Stahl
16	1	27150002	0	Installationswinkel 2 x 1/4, verz.		0,07 kg	
17	1	42200277	1	Vakuum-Zuführschlauch für BV - PUR-H		0,29 kg	Gummi
18	3	21050004	0	Norma-SCN-Drahtschelle DGH 75		0,0 kg	Federstahl
19	5	20440004	0	Scheibe DIN 9021 - A 8,4 verz.		0,00 kg	
20	2	20000046	0	Skt-Schraube 8.8 DIN 931 M8x45		0,1 kg	
21	2	20090033	0	Sechskantschraube 5/16"-24UNFx1 1/4 Ig		0,0 kg	
22	2	20000026	0	Skt-Schraube DIN 24017 verz. M12x40		0,37 kg	
23	2	20530047	0	Spannstift EN 8752, Ø4x50-St			
24	2	20000021	0	Skt.Schraube ISO 4017 - M10 x 45		0,1 kg	
25	2	20100005	0	Skt-Mutter DIN 934 M10 verzinkt		0,04 kg	
26	1	20000012	0	Skt.-Schraube ISO 4017 - M8 x 35 verz.		0,02 kg	
27	1	42200028	1	Spannband mit Gewindestift		0,18 kg	
28	7	20100015	0	Skt-Mutter EN ISO 10511 M8		0,01 kg	
29	4	21070001	0	Gummipuffer Dm 50x40/M10		0,09 kg	Gummi
30	4	20000014	0	Skt.-Schraube EN 24017 - M10 x 12 verzinkt		0,00 kg	
31	1	21070075	0	Gummischlauch 30x10x15 lg		0,0 kg	Gummi
32	1	42200470	0	Wärmeabfuhrblech komplett		0,84 kg	
33	1	22140206	0	Gerade Einschraubverschraubung M20x1,5-R 1/4 aus 15-280/S14M		0,1 kg	
34	1	22140492	0	Winkel - AG/AG Verschr. R 1/4		0,0 kg	
35	1	22060036	0	Minikugelhahn, Typ ART 125R1/4IG, iG/iG - 1/4		0,1 kg	
36	1	22140493	0	Winkel-Einschraub Verschraubung 1/4-aG/aG		0,1 kg	
37	1	22000582	0	HD-Schlauch 2SN NW8x200 ES DKO 10L- AS DKO 10L		0,5 kg	
38	1	21070090	0	HD-PE-Schraubstopfen		0,0 kg	PE
39	1	21050164	0	Rohrklemme RK		0,1 kg	
40	1	20020138	0	Zylinderschraube DIN 912 M4 x 16		0,0 kg	
41	2	20100022	0	Skt-Mutter DIN EN ISO 10511 - M4		0,0 kg	
42	1	20020036	0	Zyl.-Schraube DIN 912 M4 x 10		0,0 kg	
43	2	20100017	0	Skt-Mutter EN ISO 10511 - M12		0,01 kg	
44	1	20000008	0	Skt-Schraube DIN 933 - M8 x 16 - 8.8, verz.		0,16 kg	



© all rights reserved conform to ISO 16016

Benennung		Gebläse + B-Motor GXV390 kompl.	
mit E-Start für BV-B			
Artikelnummer/Zeichnungsnummer		E42200472	
Blatt		1	
von		1	
Zust.	Urspr.	Ers. f.	Ers. d.



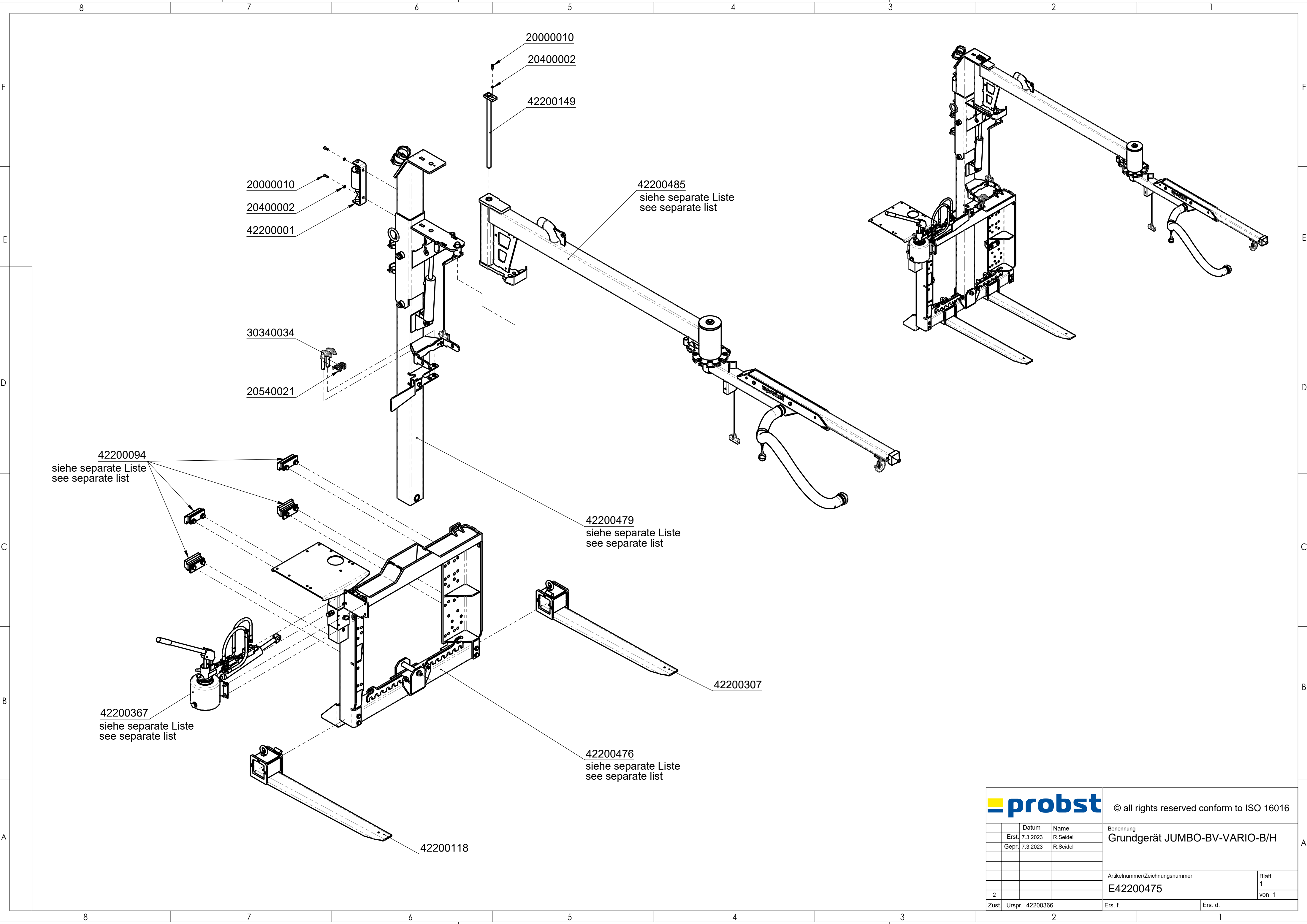

		© all rights reserved conform to ISO 16016	
	Datum	Name	Benennung
	Erst. 7.3.2023	R.Seidel	Grundgerät JUMBO-BV-VARIO-B/H
	Gepr. 7.3.2023	R.Seidel	
			Artikelnummer/Zeichnungsnummer
			E42200475
			Blatt 1 von 1
Zust.	Urspr. 42200366	Ers. f.	Ers. d.

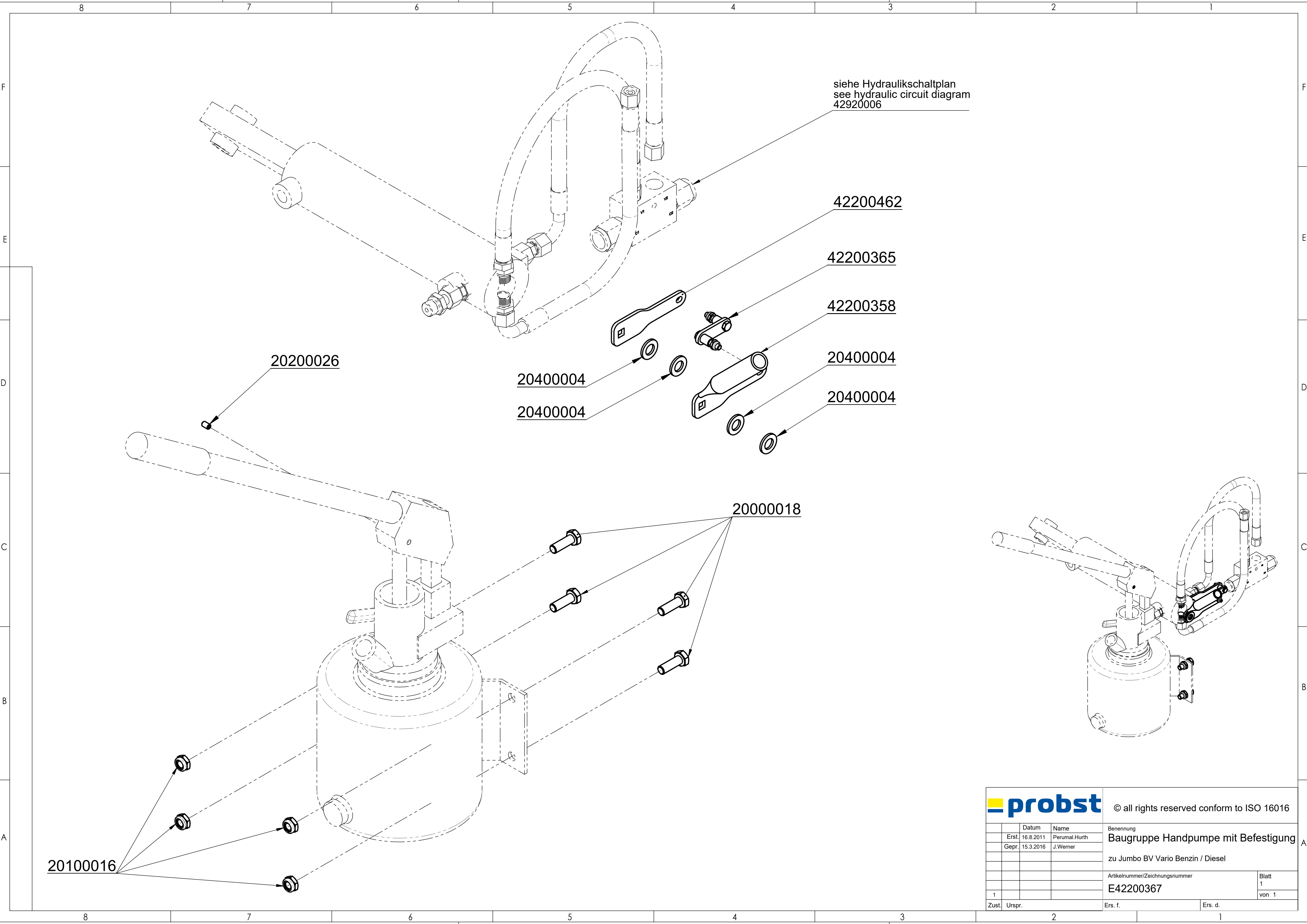

siehe Hydraulikschaltplan  
see hydraulic circuit diagram  
42920006

20200026

20400004

20400004

42200462

42200365

42200358

20400004

20400004

20000018

20100016

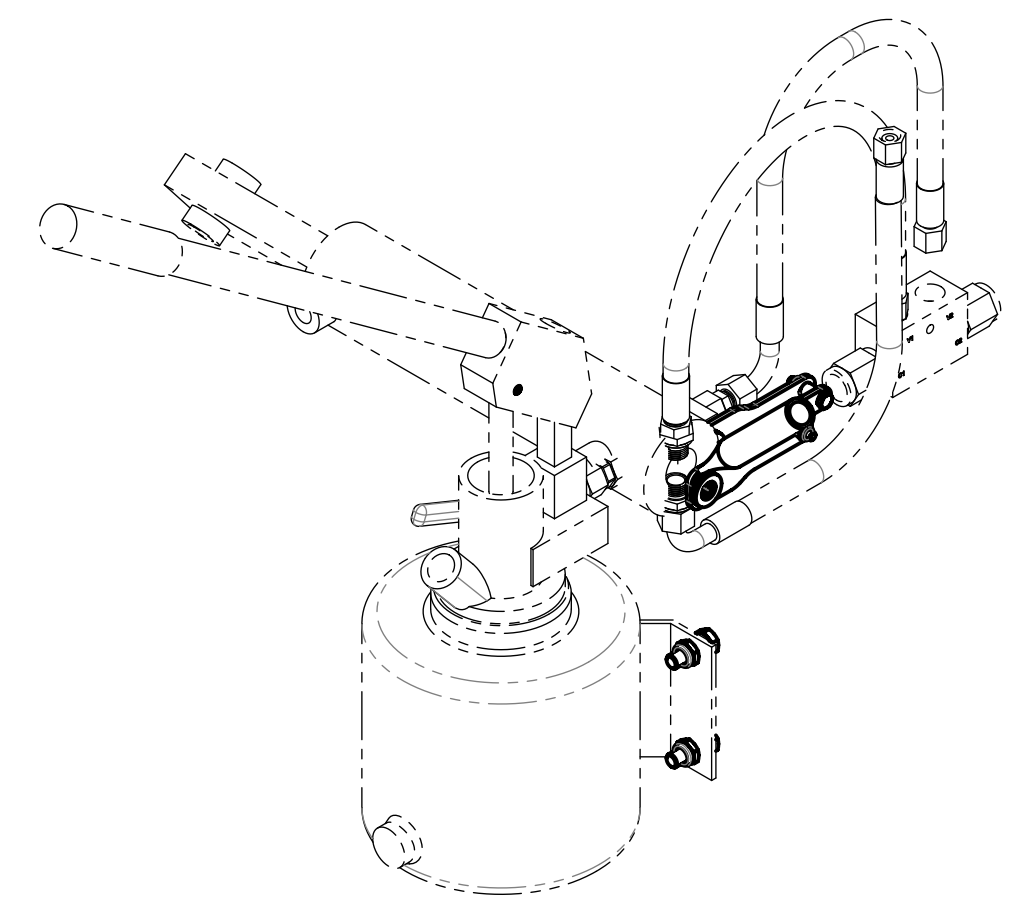

			© all rights reserved conform to ISO 16016	
Benennung			Baugruppe Handpumpe mit Befestigung	
zu Jumbo BV Vario Benzin / Diesel				
Artikelnummer/Zeichnungsnummer			Blatt	
E42200367			1	
			von 1	
Zust.	Urspr.	Ers. f.	Ers. d.	



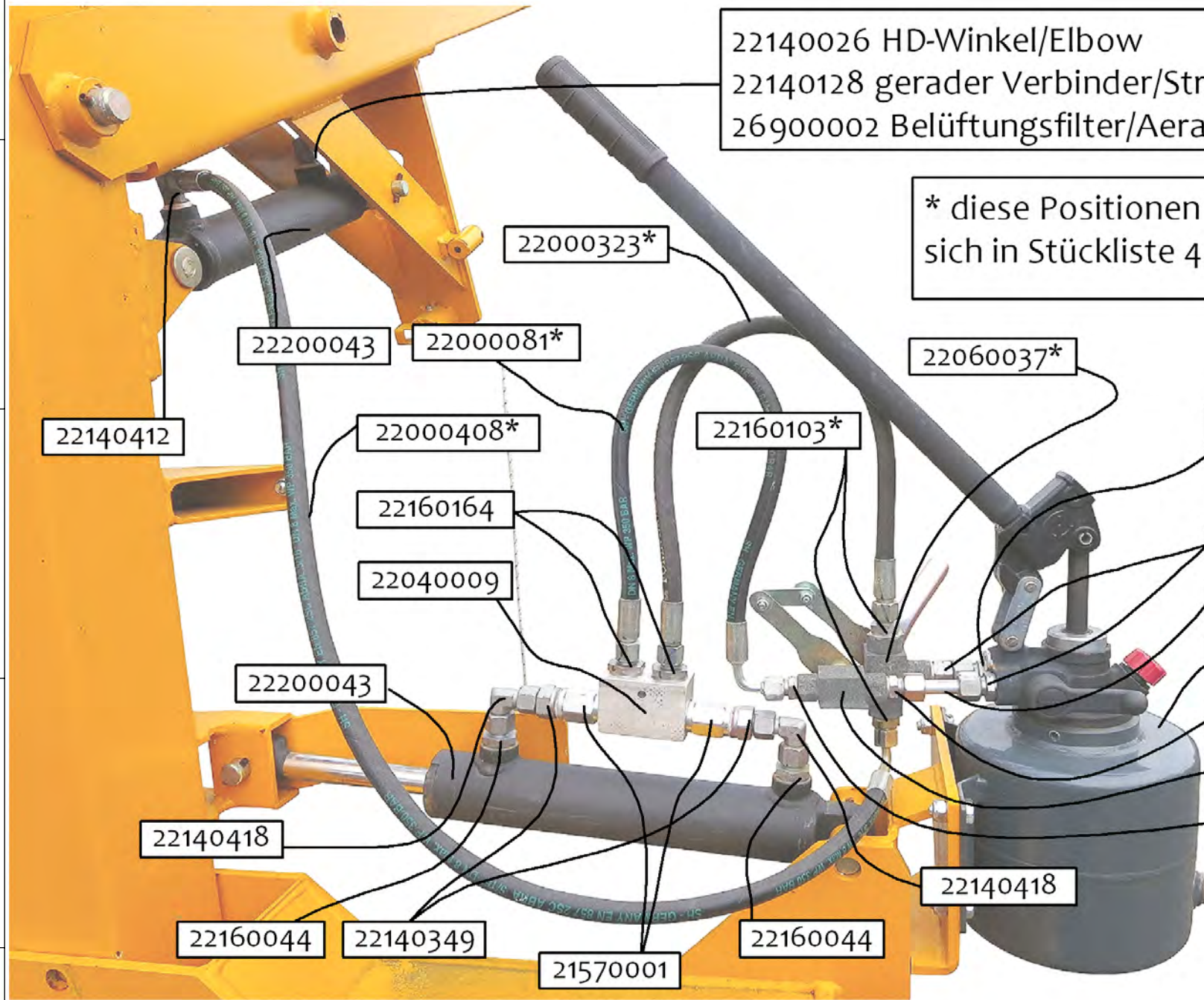

22140026 HD-Winkel/Elbow  
 22140128 gerader Verbinder/Straight link  
 26900002 Belüftungsfilter/Aeration filter

\* diese Positionen befinden sich in Stückliste 42200497

- 22000323\*
- 22200043
- 22000081\*
- 22000408\*
- 22160164
- 22040009
- 22160103\*
- 22060037\*
- 22140434\*
- 22160030\*
- 33160010\*
- 22600015\*
- 22160045\*
- 22060038\*
- 22160117\*
- 22140412
- 22200043
- 22140418
- 22160044
- 22140349
- 21570001
- 22160044
- 22140418

HD-Zylinder Querneigung Mast  
 Hydr. Cylinder Cross Levelling

HD-Zylinder Aufrichten Mast  
 Hydr. Cylinder Upraising Mast

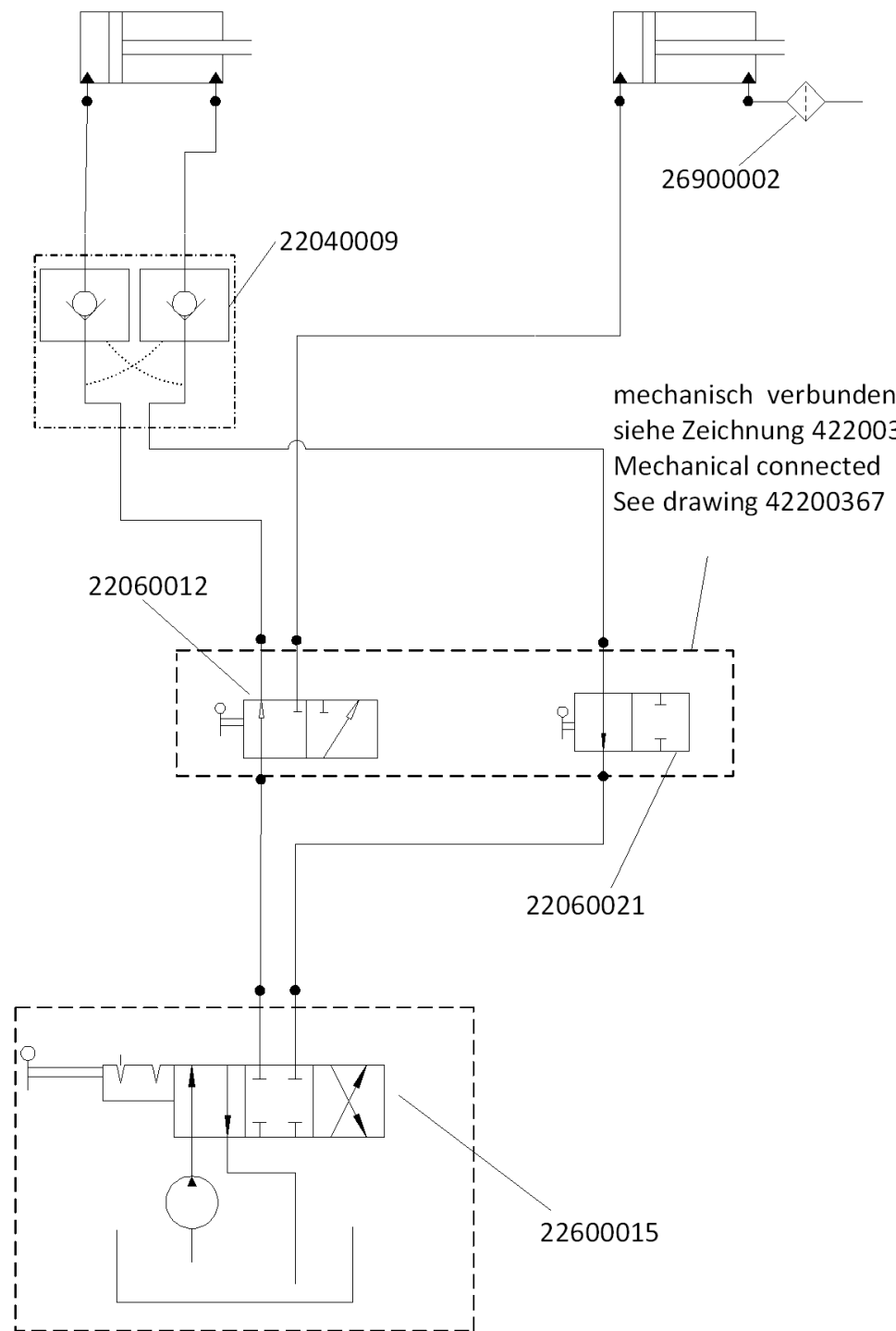

mechanisch verbunden  
 siehe Zeichnung 42200367 //  
 Mechanical connected  
 See drawing 42200367

Für Maße, ohne Toleranzangaben gelten folgende Normen		Spanen + Biegen	Schweißkonstruktionen	Thermisches Schneiden
Längen, Winkelmaße, Rundungshalbmesser & Fasenhöhe		DIN EN ISO 2768-m	DIN EN ISO 13920-A	t ≤ 20 mm DIN EN ISO 9013-341
Geradheit / Ebenheit, sowie Form und Lage		DIN EN ISO 2768-K	DIN EN ISO 13920-E	t > 20 mm DIN EN ISO 9013-342
<b>probst</b>		Maße DIN EN ISO14405	Keine Änderungen ohne Rücksprache mit TB!	
		Oberflächen nach DIN EN ISO 1302	allgemeiner Biegehalbmesser = Blechstärke	
Fehlende Maße sind dem 3D-Modell zu entnehmen. Fertigteil ist Maßgebend				
		Das Dokument ist Freigegeben	© all rights reserved conform to ISO 16016	
		Oberflächenbehandlung	Gewicht:                      Werkstoff:	
		Farbe:	Benennung <b>HD-Schaltplan JUMBO-BV-VARIO-B/D/H</b>	
4	22140418 war 452; *	15.9.2023	SR	
3	Zg. überarbeitet	24.11.2014	RN	Datum    Name
2	Pos.27,36,38 geänd.	21.11.2014	RN	Erst. 12.4.2010    Perumal.Hurth
1	mit Drossel 22060021	8.12.2021	SR	Gepr. 15.9.2023    R.Seidel
Zust.	Änderungstext	Datum	von	Urspr.
			Artikelnummer/Zeichnungsnummer	
			42920006	
				Blatt 1 von 1
				Maßstab 1:1
				Blattformat A3

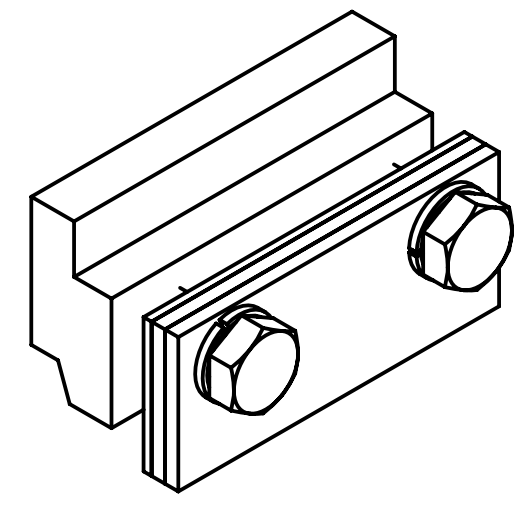
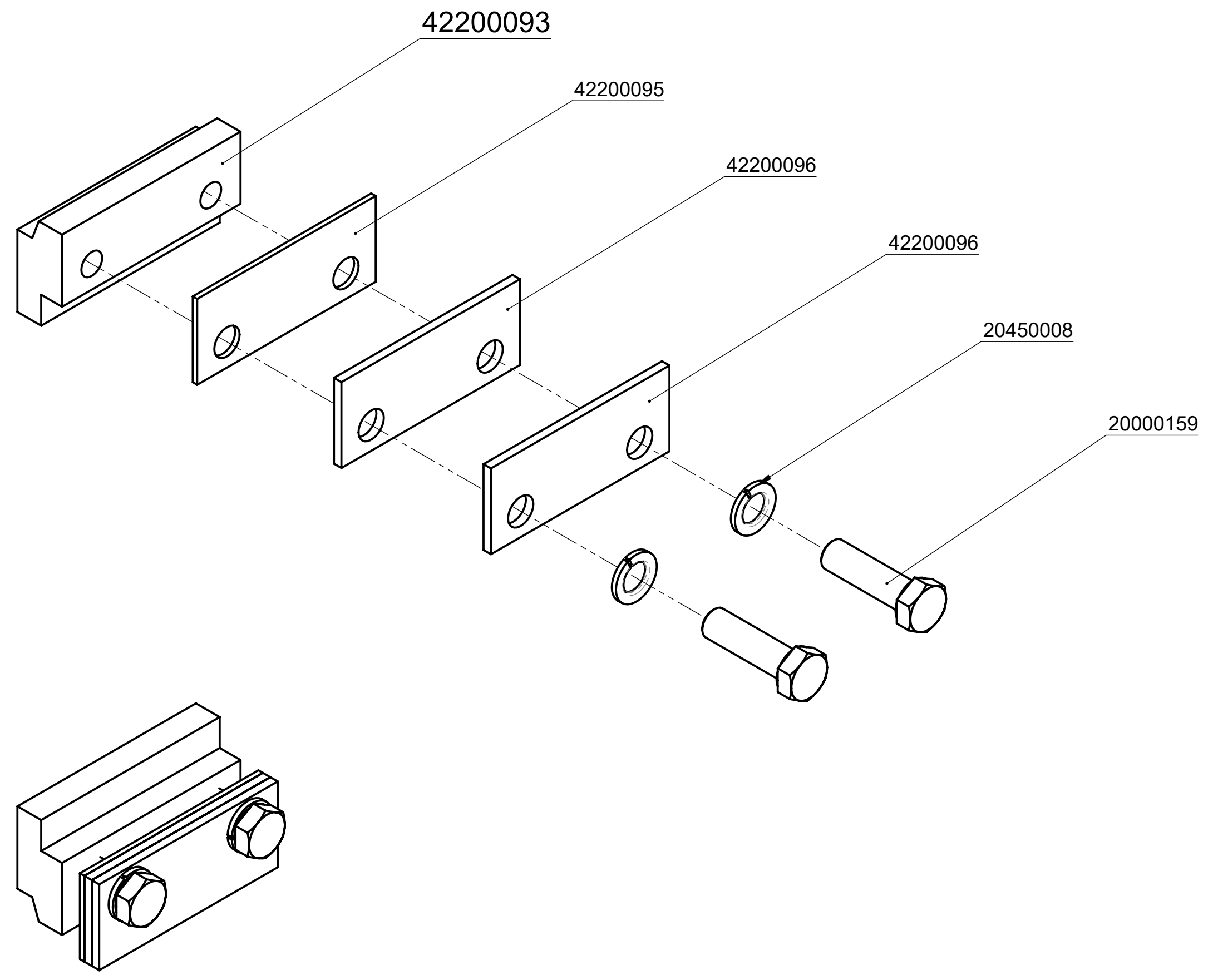
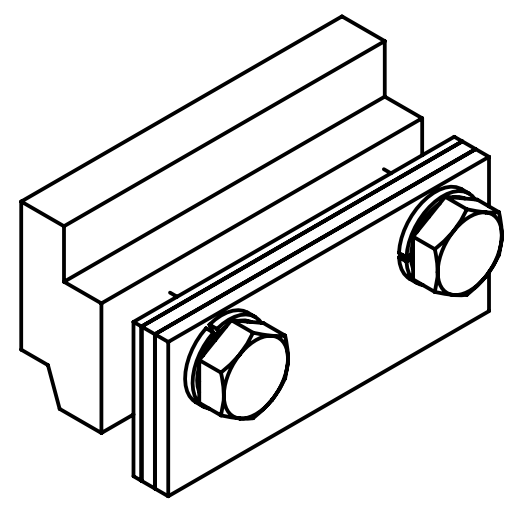
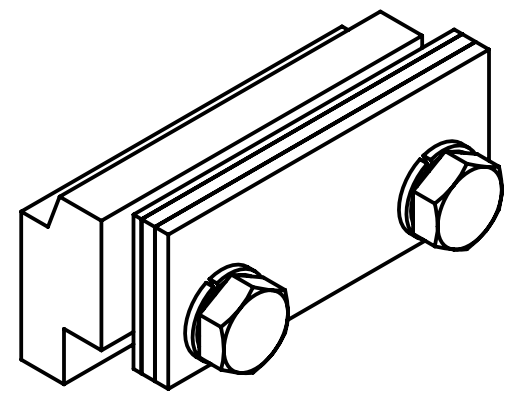
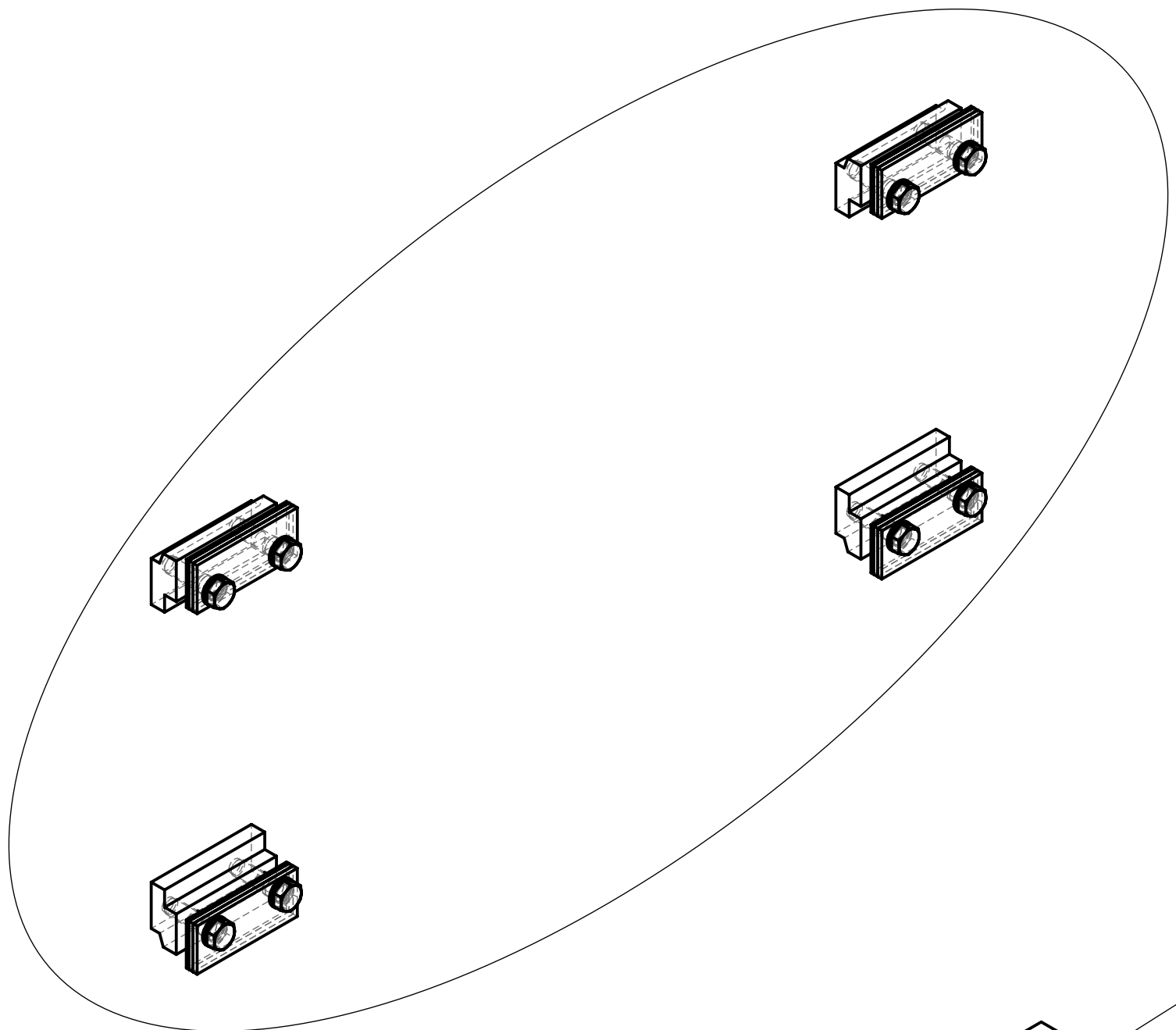

		© all rights reserved conform to ISO 16016	
	Datum	Name	Benennung
	Erst. 7.5.2019	R.Seidel	Set Prätzen-Uni mit Unterlagen 3 und 5 mm
	Gepr. 7.5.2019	R.Seidel	
			Artikelnummer/Zeichnungsnummer
			E42200094
			Blatt 1 von 1
Zust.	Urspr.	Ers. f.	Ers. d.



20540001

20530013

20000035

20100018

20440008

42200004

20000092

20100019

20000057

21720001

21720001

20000169

20100016

20100018

20440008

20000092

42200004

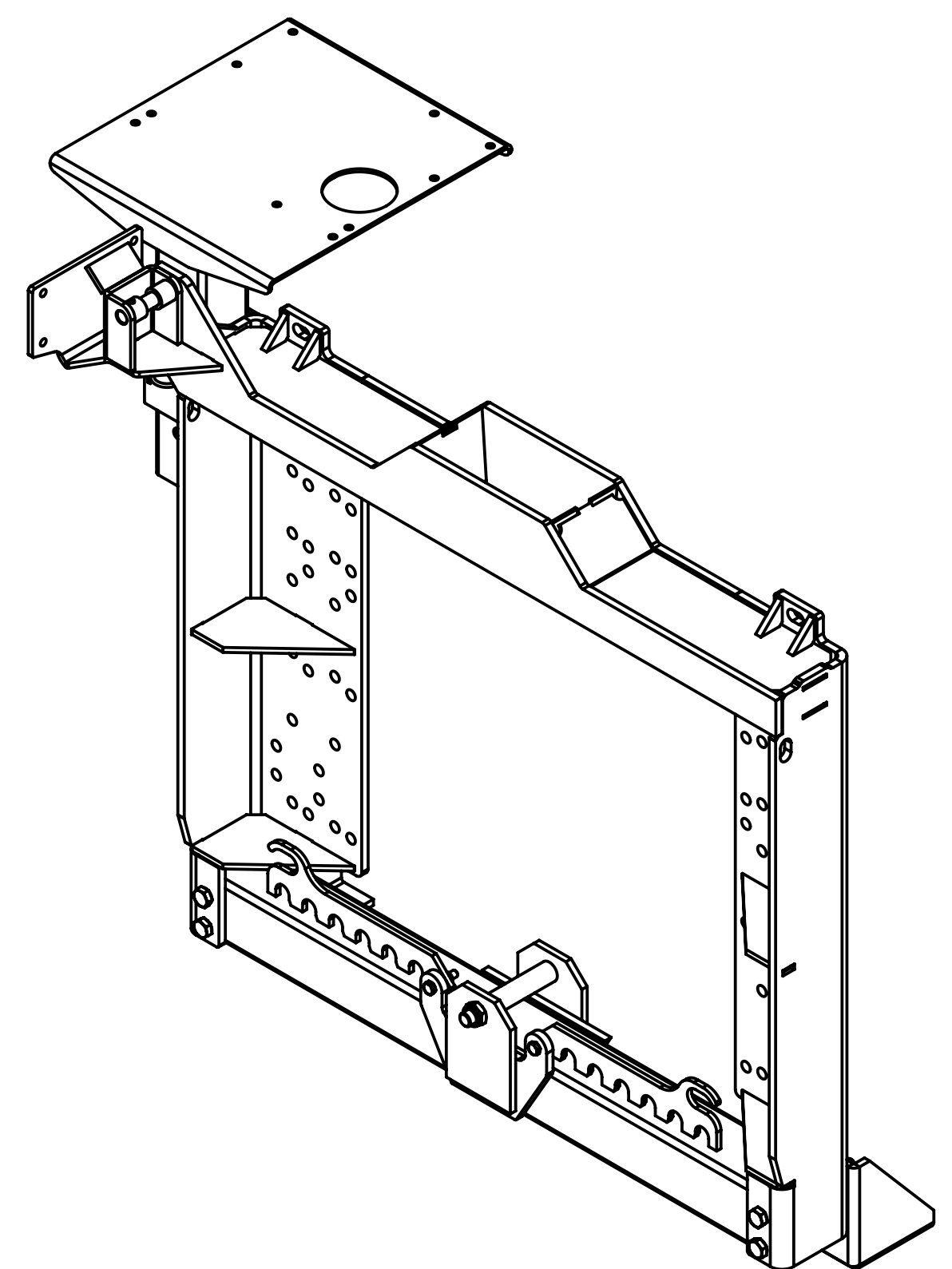

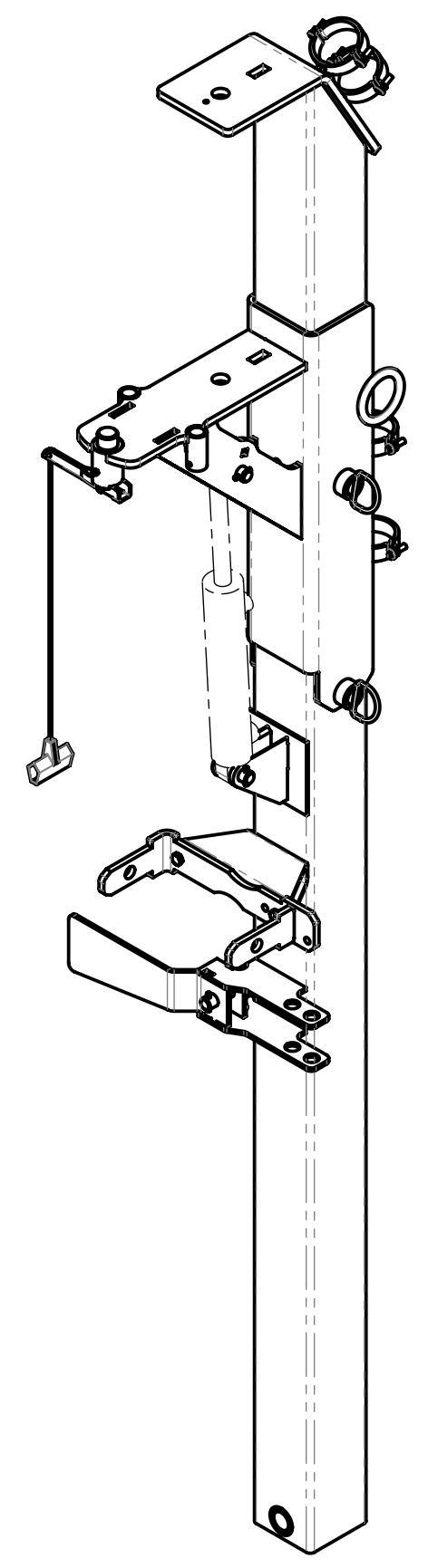
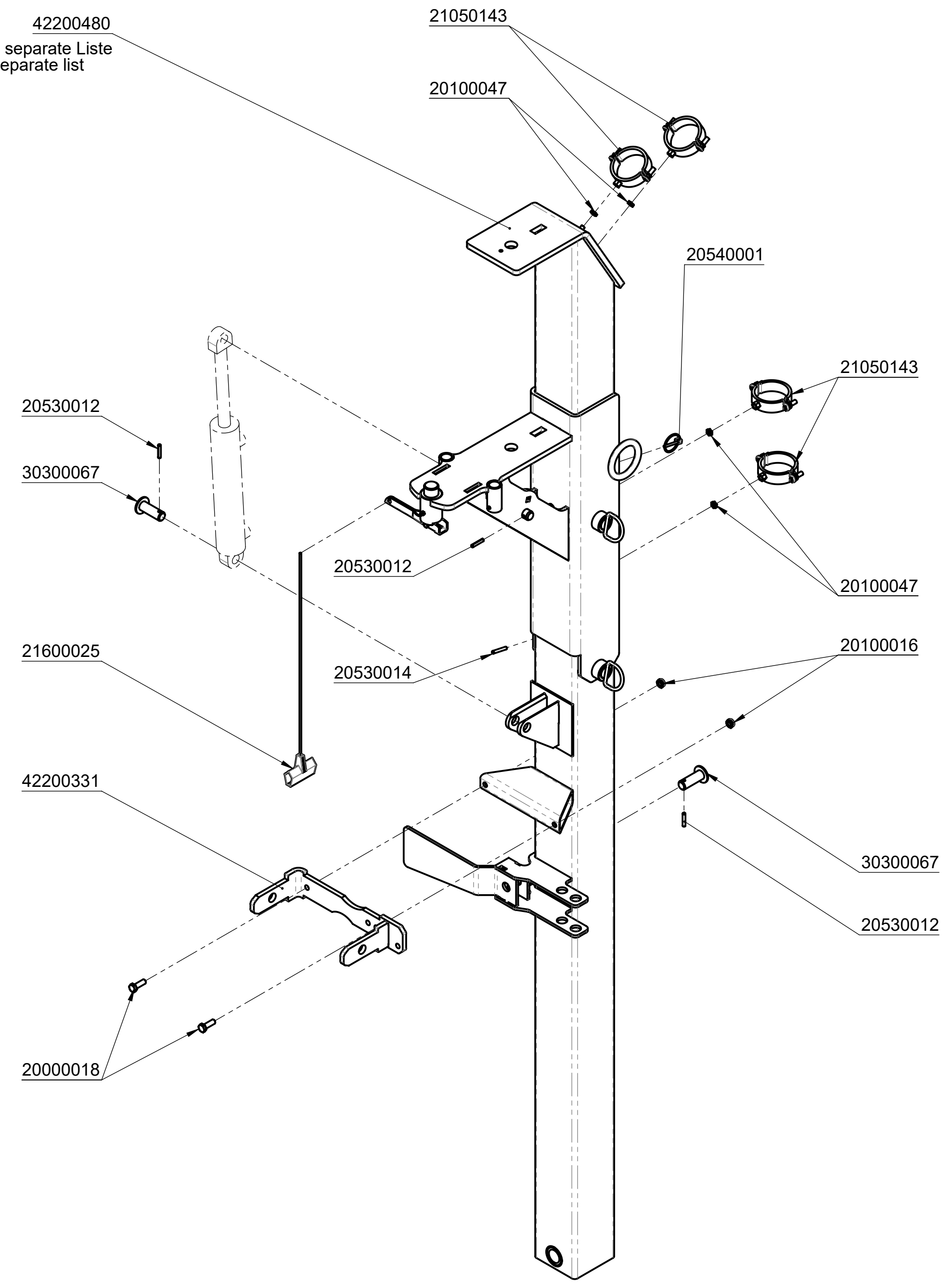

		© all rights reserved conform to ISO 16016	
	Datum	Name	Benennung
	Erst. 5.8.2021	R.Northe	Rahmen für BV komplett
	Gepr. 7.3.2023	R.Seidel	
			Artikelnummer/Zeichnungsnummer
			E42200476
1			Blatt 1 von 1
Zust.	Urspr. 42200354	Ers. f.	Ers. d.

42200480  
siehe separate Liste  
see separate list

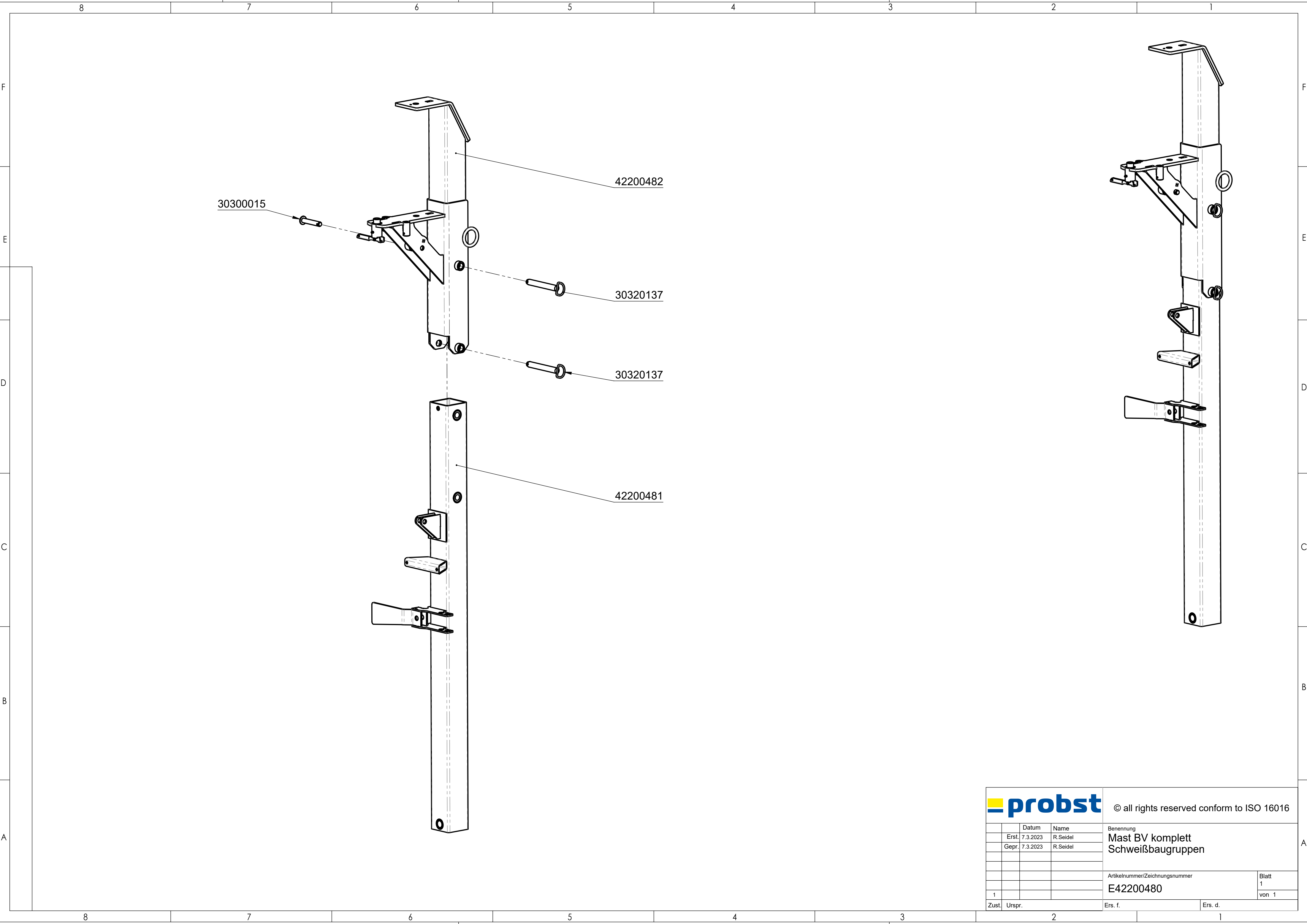

			© all rights reserved conform to ISO 16016	
	Datum	Name	Benennung	
	Erst. 7.3.2023	R.Seidel	Mast BV komplett mit Anbauteilen	
	Gepr. 23.3.2023	R.Seidel		
			Artikelnummer/Zeichnungsnummer	
			E42200479	
1			Blatt 1 von 1	
Zust.	Urspr. 42200356	Ers. f.	Ers. d.	



			© all rights reserved conform to ISO 16016		
	Datum	Name	Benennung		
	Erst. 7.3.2023	R.Seidel	Mast BV komplett		
	Gepr. 7.3.2023	R.Seidel	Schweißbaugruppen		
			Artikelnummer/Zeichnungsnummer		Blatt
			E42200480		1
1					von 1
Zust.	Urspr.		Ers. f.		Ers. d.

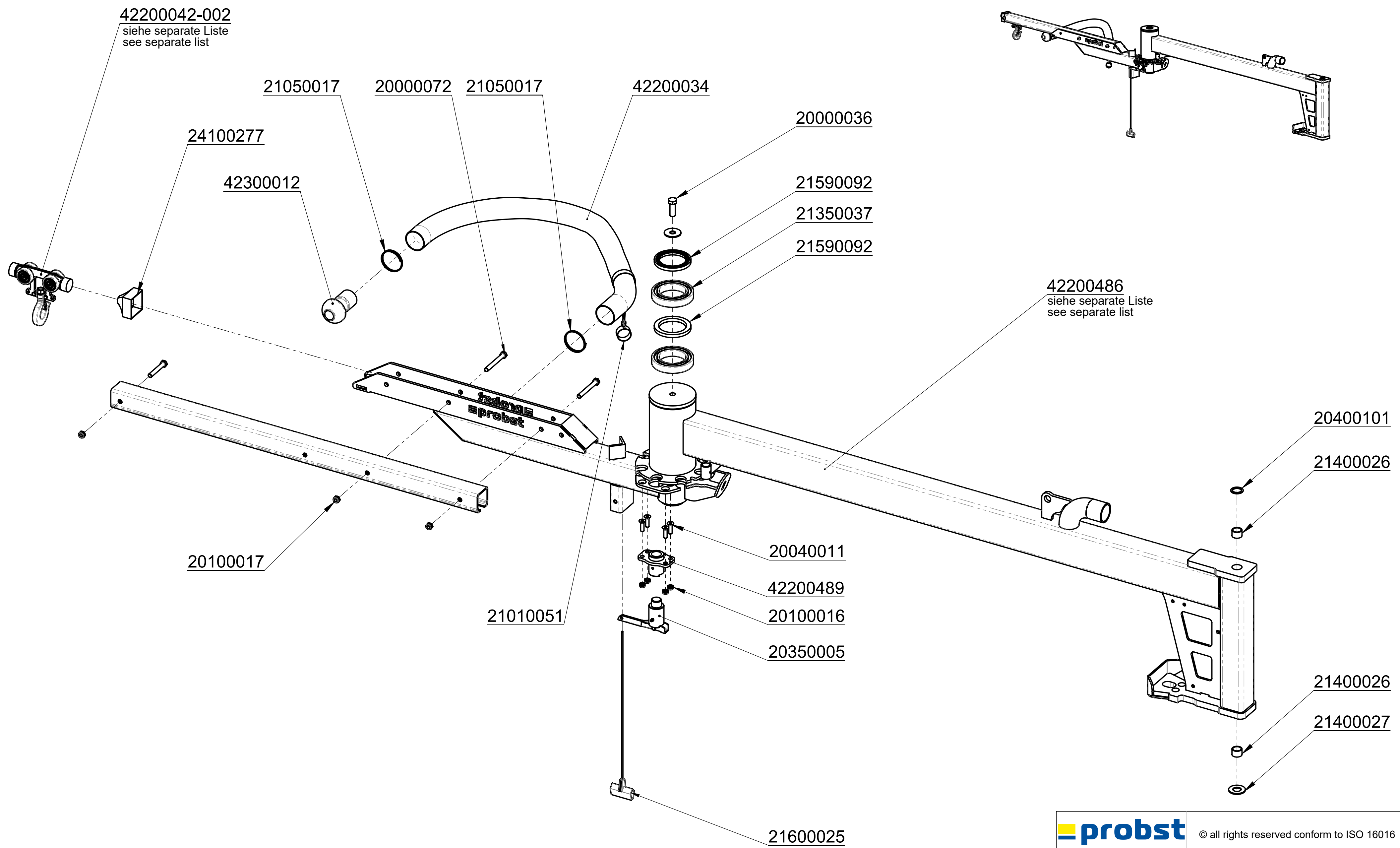

42200042-002  
siehe separate Liste  
see separate list

42200486  
siehe separate Liste  
see separate list

- 21050017
- 20000072
- 21050017
- 42200034
- 20000036
- 21590092
- 21350037
- 21590092
- 24100277
- 42300012
- 20400101
- 21400026
- 20100017
- 21010051
- 20040011
- 42200489
- 20100016
- 20350005
- 21600025

		© all rights reserved conform to ISO 16016	
	Datum	Name	Benennung
	Erst. 20.8.2019	R.Northe	Knickausleger komplett BV/JM
	Gepr. 24.3.2023	R.Seidel	
			Artikelnummer/Zeichnungsnummer
			E42200485
1			Blatt 1 von 1
Zust.	Urspr. 42200333	Ers. f.	Ers. d.



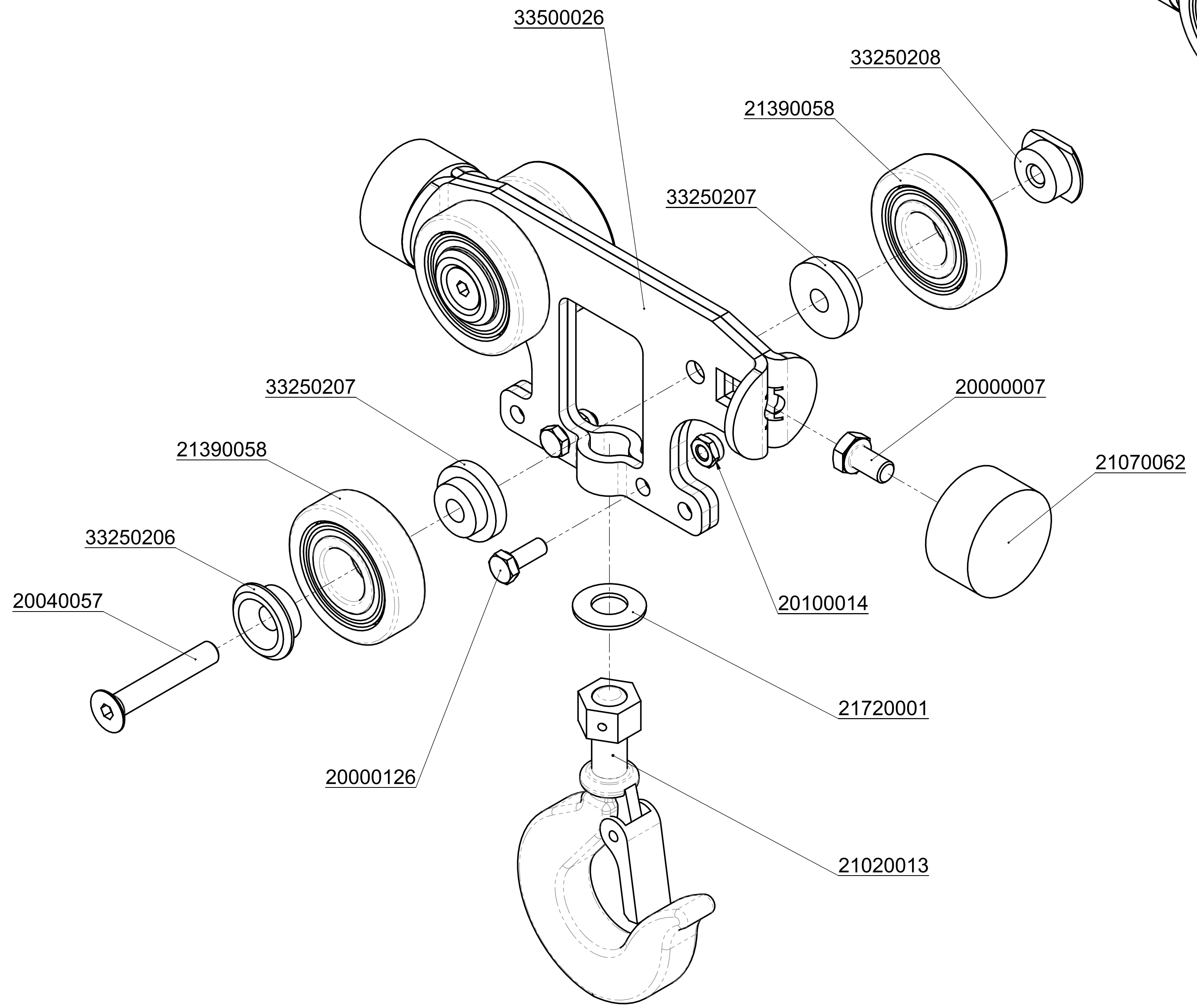
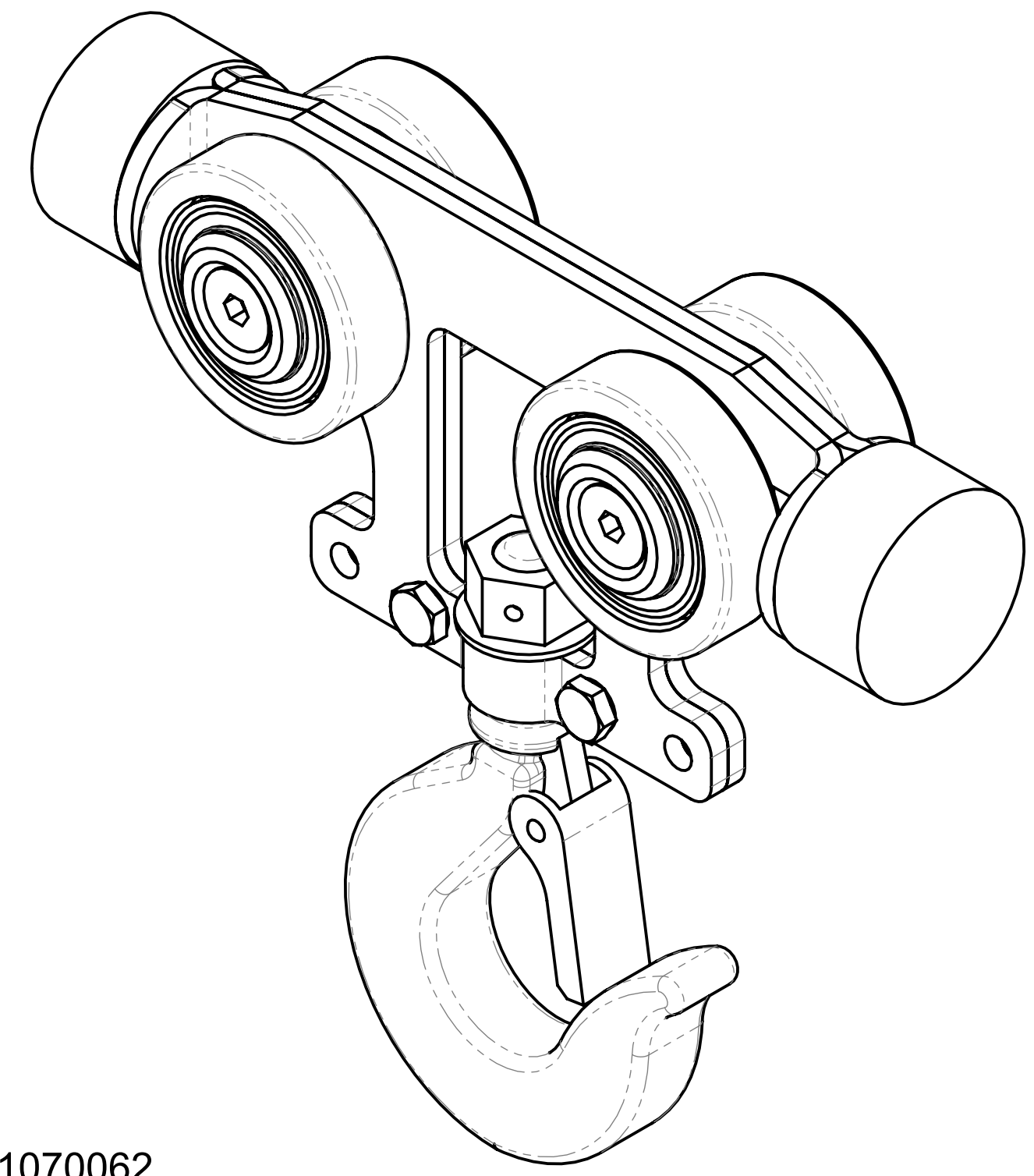

		© all rights reserved conform to ISO 16016	
	Datum	Name	Benennung
	Erst. 7.4.2020	R.Seidel	Laufwagen mit alternativer Rolle
	Gepr. 7.4.2020	R.Seidel	Import Laufrolle baugleich SKF 361204R
			Artikelnummer/Zeichnungsnummer
			E42200042-002
			Blatt 1 von 1
Zust.	Urspr.	Ers. f.	Ers. d.

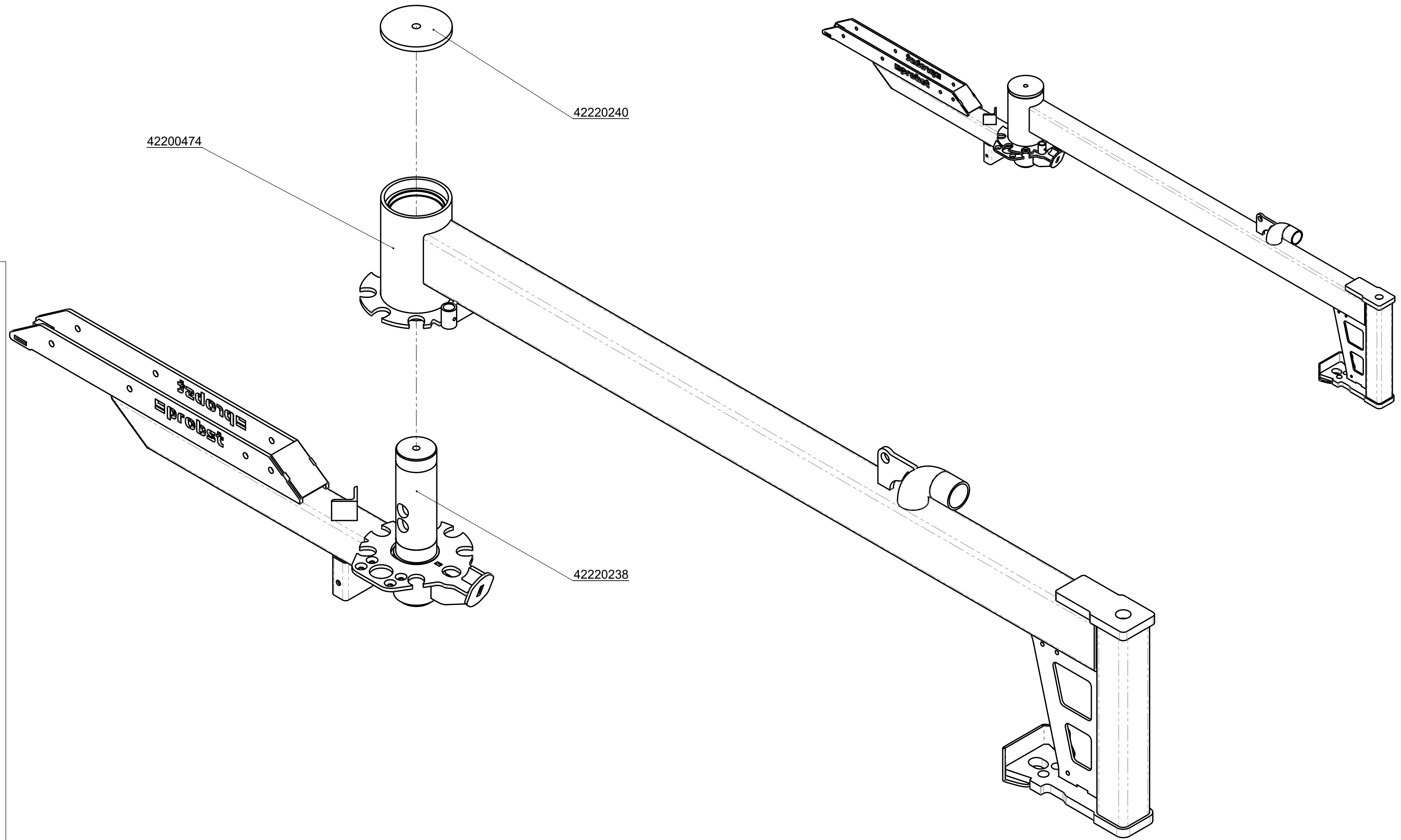

4220074

42220240

42220238

		© all rights reserved conform to ISO 16016	
	Datum	Name	
	Erst. 20.8.2019	R.Northe	
	Gepr. 27.3.2023	R.Seidel	
		Benennung	
		Knickausleger komplett BV/JM	
		Schweißbaugruppen	
		Artikelnummer/Zeichnungsnummer	Blatt
		E42200486	1
			von 1
1	Zust.	Urspr. 42200446	Ers. f.
			Ers. d.

A52200016 Jumbo-BV-VARIO-B  
 A52200016-150 Jumbo-BV-VARIO-150-B  
 A52200016-200 Jumbo-BV-VARIO-200-B  
 A52200016-250 Jumbo-BV-VARIO-250-B

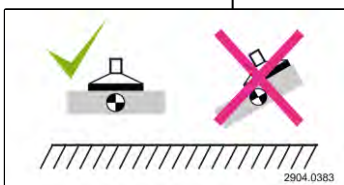
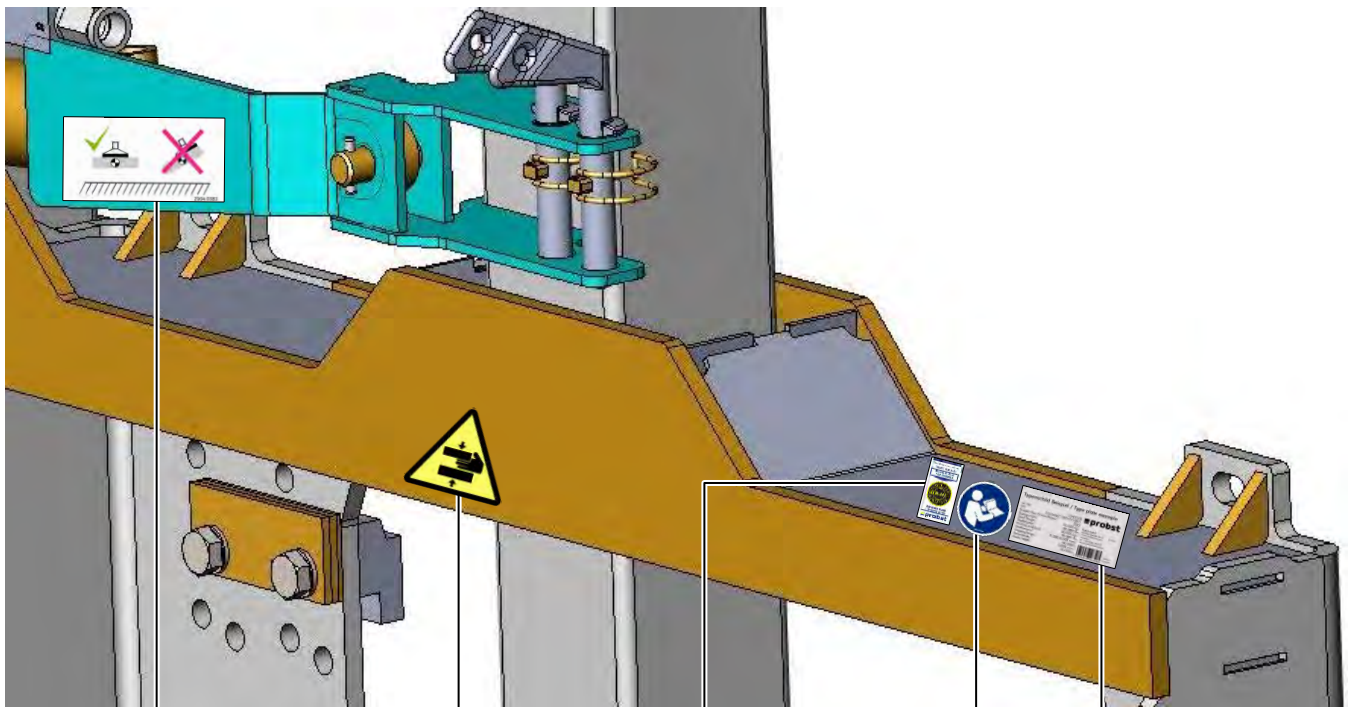

29040383



29040107



29040056



29040666

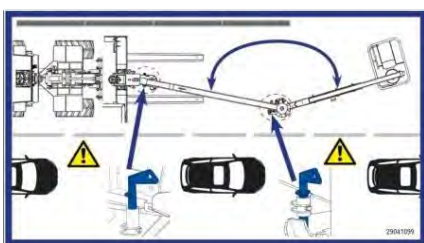

29041099

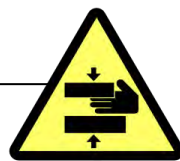

29040107



29040204



29040562





A52200016 Jumbo-BV-VARIO-B  
 A52200016-150 Jumbo-BV-VARIO-150-B  
 A52200016-200 Jumbo-BV-VARIO-200-B  
 A52200016-250 Jumbo-BV-VARIO-250-B

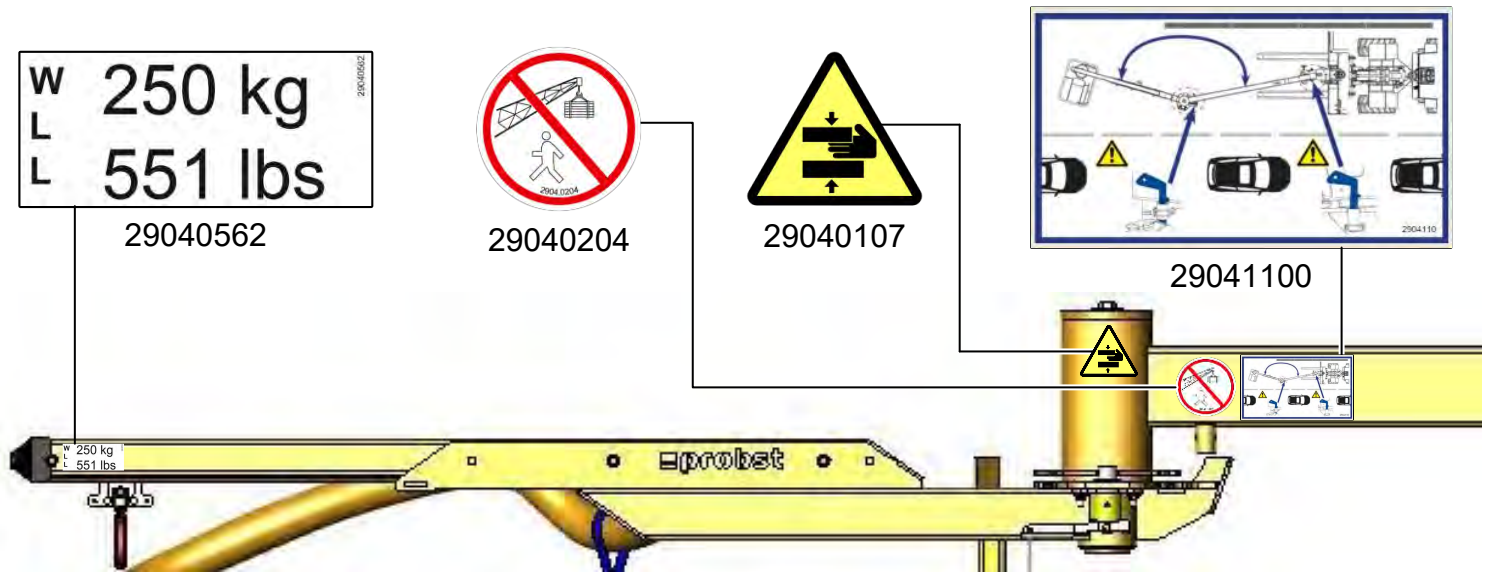

29040370  
 Auf beiden  
 Seiten / on  
 both sides

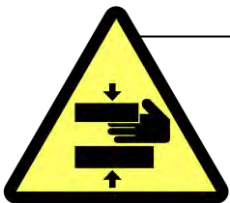

29040107  
 Auf beiden  
 Seiten / on  
 both sides

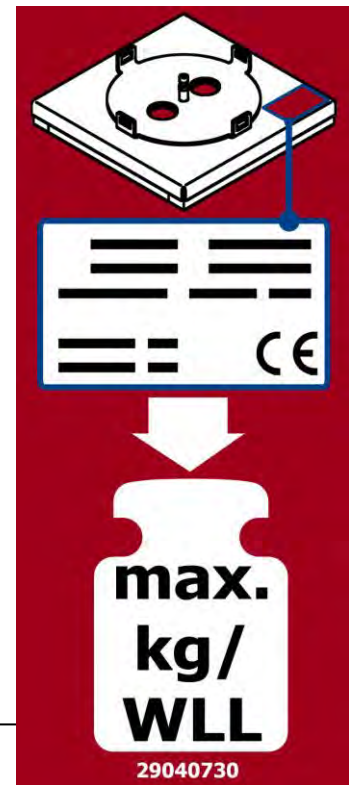
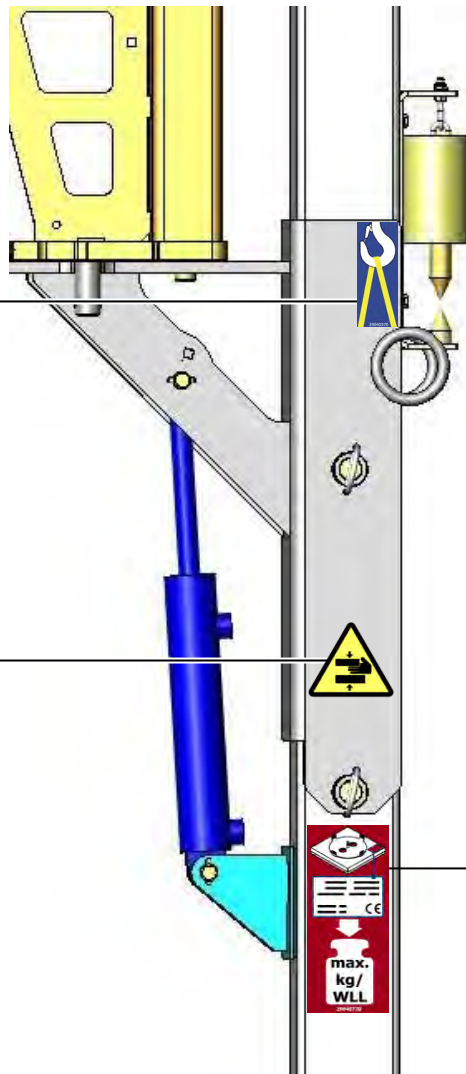

29040730

**A52200016 Jumbo-BV-VARIO-B**  
**A52200016-150 Jumbo-BV-VARIO-150-B**  
**A52200016-200 Jumbo-BV-VARIO-200-B**  
**A52200016-250 Jumbo-BV-VARIO-250-B**

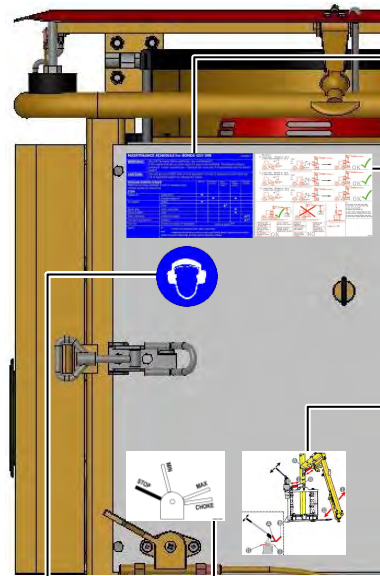

MAINTENANCE SCHEDULE for HONDA GXV 340						
<b>WARNING:</b> Shut off the engine before performing any maintenance! (If the engine starts by itself, while the area is well ventilated. The exhaust contains poisonous carbon monoxide gas - exposure can cause loss of consciousness and may lead to death!)						
<b>CAUTION:</b> Use only genuine HONDA parts or their equivalent! The use of replacement parts which are not of equivalent quality may damage the engine.						
<b>REGULAR SERVICE PERIOD</b> Perform at every indicated month or operating hour interval, whichever applies first.						
ITEM	Frequency	50 hours or 1 month	100 hours or 2 months	200 hours or 4 months	400 hours or 8 months	800 hours or 16 months
Change oil	check level (change engine oil)	•	•	•	•	•
Air cleaner	clean	•	•	•	•	•
Spark plug	check and clean	•	•	•	•	•
Spark arrester	clean	•	•	•	•	•
Water clearance	check and adjust	•	•	•	•	•
Fuel tank and strainer	cleaning	•	•	•	•	•
Fuel filter	check and replace if necessary	•	•	•	•	•
WFO:	• maintenance heavily stressed in this area					
	• clean lamp should be serviced by an authorized HONDA dealer, unless the owner has the proper tools and is mechanically proficient, see the service for the proper tools and is mechanically proficient, see the service for the					

29040329 (DE)  
 29040330 (GB)  
 29040331 (FR)

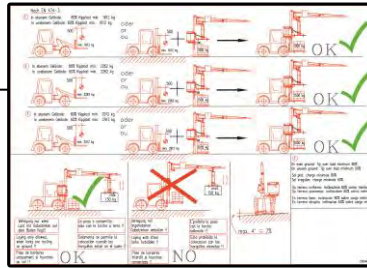

29040339

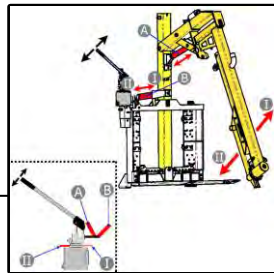

29040476

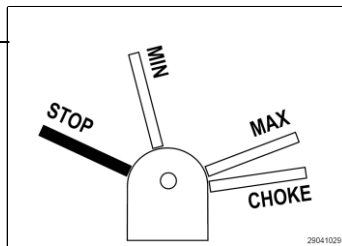

29041029



29040298



29040687



29040624



**MIN. 91 ROZ/RON**  
 Nur bleifreies Benzin / Unleaded fuel only  
 Carburant sans plomb / Solo bezina senza piombo  
 Solo gasolina sin plomo

29040340

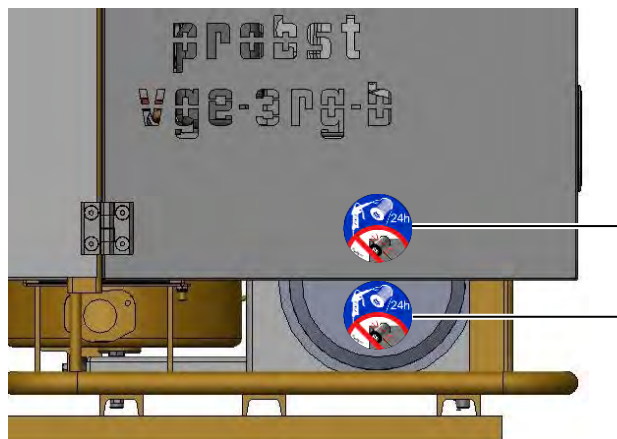

29040451

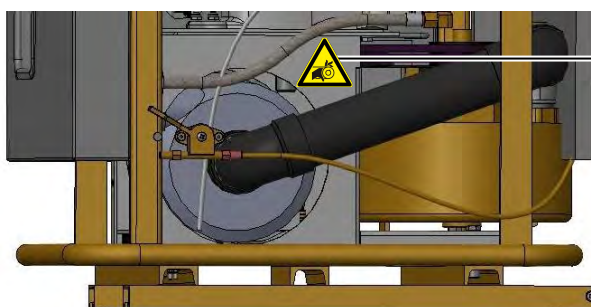

29040396

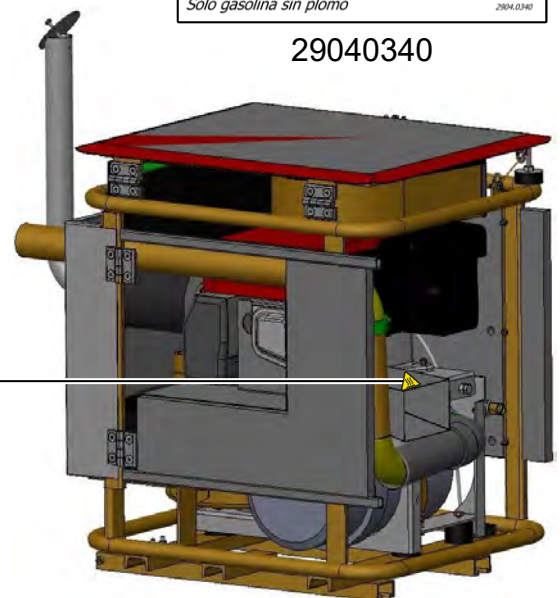



A52200016 Jumbo-BV-VARIO-B  
 A52200016-150 Jumbo-BV-VARIO-150-B  
 A52200016-200 Jumbo-BV-VARIO-200-B  
 A52200016-250 Jumbo-BV-VARIO-250-B

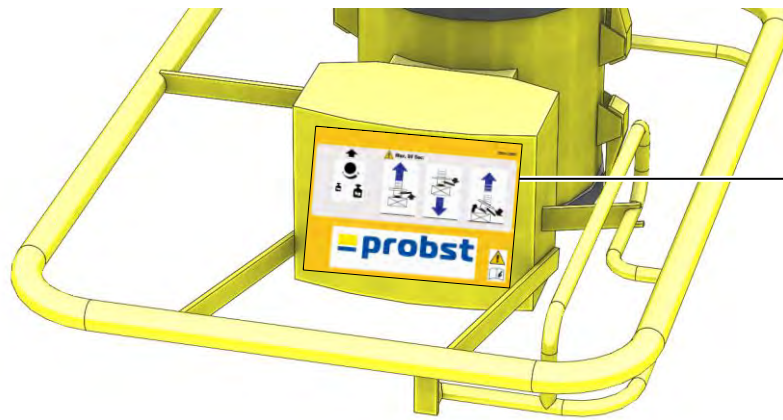

29040384



29040666

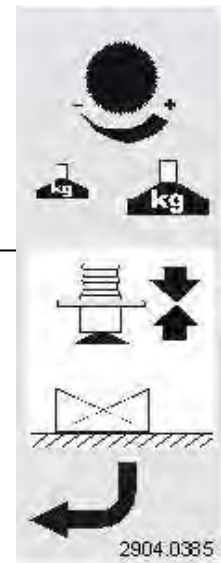
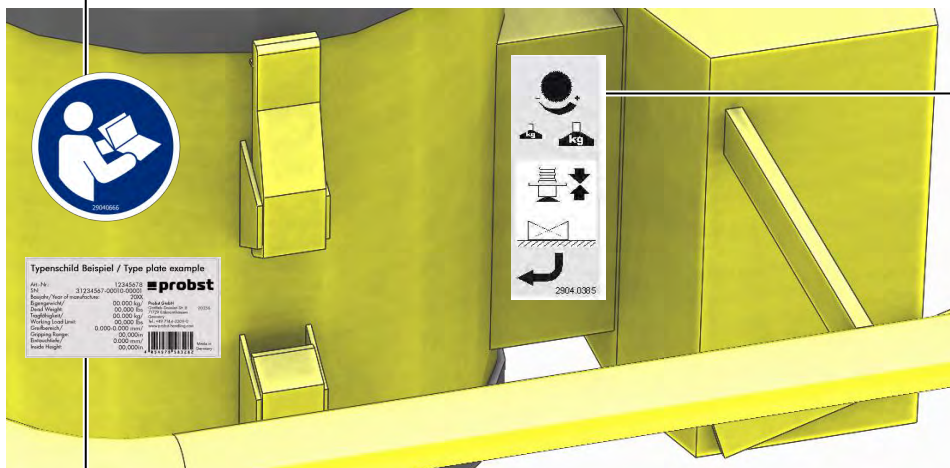

29040385

Typenschild Beispiel / Type plate example	
Art.-Nr.:	12345678
SN:	31234567-00010-00001
Baujahr/Year of manufacture:	20XX
Eigengewicht/Dead Weight:	00,000 kg/00,000 lbs
Tragfähigkeit/Working Load Limit:	00,000 kg/00,000 lbs
Greifbereich/Gripping Range:	0,000-0,000 mm/0,000-0,000 in
Eintauchtiefe/Inside Height:	0,000 mm/0,000 in

Typenschild  
Bedieneinheit

Typenschild Beispiel / Type plate example	
Art.-Nr.:	12345678
SN:	31234567-00010-00001
Baujahr/Year of manufacture:	20XX
Eigengewicht/Dead Weight:	00,000 kg/00,000 lbs
Tragfähigkeit/Working Load Limit:	00,000 kg/00,000 lbs
Greifbereich/Gripping Range:	0,000-0,000 mm/0,000-0,000 in
Eintauchtiefe/Inside Height:	0,000 mm/0,000 in

Typenschild  
Hubeinheit

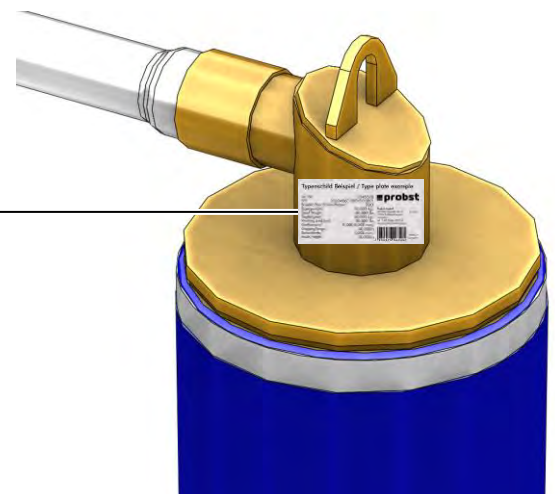



<b>DE</b>	Bitte beachten Sie, dass das Produkt ohne vorliegende Betriebsanleitung in Landessprache nicht eingesetzt / in Betrieb gesetzt werden darf. Sollten Sie mit der Lieferung des Produkts keine Betriebsanleitung in Ihrer Landessprache erhalten haben, kontaktieren Sie uns bitte. In Länder der EU / EFTA senden wir Ihnen diese kostenlos nach. Für Länder außerhalb der EU / EFTA erstellen wir Ihnen gerne ein Angebot für eine Betriebsanleitung in Landessprache, falls die Übersetzung nicht durch den Händler/Importeur organisiert werden kann.
<b>GB</b>	Please note that the product may not be used / put into operation without these operating instructions in the national language. If you did not receive operating instructions in your national language with the delivery of the product, please contact us. In countries of the EU / EFTA we will send them to you free of charge. For countries outside the EU / EFTA, we will be pleased to provide you with an offer for an operating manual in the national language if the translation cannot be organised by the dealer/importer.
<b>FR</b>	Veillez noter que le produit ne doit pas être utilisé / mis en service sans le présent mode d'emploi dans la langue du pays. Si vous n'avez pas reçu de mode d'emploi dans votre langue lors de la livraison du produit, veuillez nous contacter. Dans les pays de l'UE / AELE, nous vous l'enverrons gratuitement. Pour les pays en dehors de l'UE / AELE, nous vous soumettons volontiers une offre pour un mode d'emploi dans la langue du pays si la traduction ne peut pas être organisée par le revendeur / l'importateur.
<b>IT</b>	Si prega di notare che il prodotto non può essere utilizzato/messo in funzione senza le istruzioni per l'uso nella lingua locale. Se con la consegna del prodotto non avete ricevuto le istruzioni per l'uso nella vostra lingua nazionale, contattateci. Le invieremo gratuitamente nei Paesi UE/EFTA. Per i Paesi al di fuori dell'UE/EFTA, saremo lieti di fornirvi un preventivo per le istruzioni per l'uso nella lingua locale se la traduzione non può essere organizzata dal rivenditore/importatore.
<b>NL</b>	Houd er rekening mee dat het product niet mag worden gebruikt / in gebruik genomen zonder bedieningshandleiding in de lokale taal. Als u bij de levering van het product geen bedieningshandleiding in uw landstaal hebt ontvangen, neem dan contact met ons op. Wij sturen u deze gratis toe in de EU/EVA-landen. Voor landen buiten de EU/EVA doen wij u graag een voorstel voor een gebruiksaanwijzing in de lokale taal als de vertaling niet kan worden geregeld door de dealer/importeur.
<b>ES</b>	Tenga en cuenta que el producto no puede utilizarse / ponerse en funcionamiento sin instrucciones de uso en el idioma local. Si no ha recibido las instrucciones de funcionamiento en su idioma nacional con la entrega del producto, póngase en contacto con nosotros. Se las enviaremos gratuitamente en los países de la UE / AELC. Para los países fuera de la UE / AELC, estaremos encantados de proporcionarle un presupuesto para las instrucciones de funcionamiento en el idioma local si la traducción no puede ser organizada por el distribuidor / importador.
<b>PL</b>	Należy pamiętać, że produkt nie może być używany / uruchamiany bez instrukcji obsługi w lokalnym języku. Jeśli wraz z produktem nie dostarczono instrukcji obsługi w języku danego kraju, prosimy o kontakt. Wyślemy ją bezpłatnie w krajach UE/EFTA. W przypadku krajów spoza UE / EFTA z przyjemnością przedstawimy wycenę instrukcji obsługi w języku lokalnym, jeśli sprzedawca / importer nie może zorganizować tłumaczenia.
<b>BG</b>	Моля, обърнете внимание, че продуктът не може да се използва/въвежда в експлоатация без инструкции за експлоатация на местния език. Ако с доставката на продукта не сте получили инструкции за експлоатация на вашия национален език, моля, свържете се с нас. Ние ще ви ги изпратим безплатно в страните от ЕС/ЕАСТ. За страните извън ЕС/ЕАСТ с удоволствие ще Ви предоставим оферта за инструкции за експлоатация на местния език, ако преводът не може да бъде организиран от търговеца/вносителя.
<b>DK</b>	Vær opmærksom på, at produktet ikke må anvendes / tages i brug uden en betjeningsvejledning på det lokale sprog. Hvis du ikke har modtaget en betjeningsvejledning på dit nationale sprog ved levering af produktet, bedes du kontakte os. Vi sender den gratis til dig i EU/EFTA-lande. I lande uden for EU/EFTA giver vi gerne et tilbud på en brugsanvisning på det lokale sprog, hvis oversættelsen ikke kan organiseres af forhandleren/importøren.
<b>ET</b>	Pange tähele, et toodet ei tohi kasutada / kasutusele võtta ilma kohaliku keele koostatud kasutusjuhendita. Kui te ei ole toote tarnimisel saanud kasutusjuhendit teie riigikeeles, võtke meiega ühendust. Me saadame need teile tasuta ELI/EFTA riikides. Väljaspool ELI/EFTA riike esitame teile hea meelega pakkumise kohalikus keeles kasutusjuhendi saamiseks, kui edasimüüja/importija ei saa tõlkimist korraldada.
<b>FI</b>	Huomaa, että tuotetta ei saa käyttää / ottaa käyttöön ilman paikalliskielisiä käyttöohjeita. Jos et ole saanut käyttöohjeita kansallisella kielelläsi tuotteen toimituksen yhteydessä, ota meihin yhteyttä. Lähetämme ne sinulle maksutta EU- / EFTA-maissa. EU:n / EFTA:n ulkopuolisissa maissa annamme mielellämme tarjouksen käyttöohjeista paikallisella kielellä, jos jälleenmyyjä / maahantuojia ei voi järjestää käännöstä.
<b>GR</b>	Λάβετε υπόψη ότι το προϊόν δεν επιτρέπεται να χρησιμοποιηθεί/να τεθεί σε λειτουργία χωρίς οδηγίες λειτουργίας στην τοπική γλώσσα. Εάν δεν έχετε λάβει οδηγίες λειτουργίας στην εθνική σας γλώσσα με την παράδοση του προϊόντος, παρακαλούμε επικοινωνήστε μαζί μας. Θα σας τις στείλουμε δωρεάν στις χώρες της ΕΕ / ΕΖΕΣ. Για χώρες εκτός ΕΕ / ΕΖΕΣ, θα χαρούμε να σας παραχούμε προσφορά για οδηγίες λειτουργίας στην τοπική γλώσσα, εάν η μετάφραση δεν μπορεί να οργανωθεί από τον αντιπρόσωπο / εισαγωγέα.
<b>IS</b>	Vinsamlega athugið að ekki má nota/taka í notkun vöruna nema notkunarleiðbeiningar séu á heimatungumáli. Ef þú fékkst ekki notkunarhandbók á þínu tungumáli þegar varan var afhent, vinsamlegast hafðu samband við okkur. Við munum senda þér þetta ókeypis til ESB / EFTA landa. Fyrir lönd utan ESB / EFTA munum við gjarnan veita þér tilboð um notkunarhandbók á heimatungumáli ef söluáðili/innflytjandi getur ekki skipulagt þýðinguna.
<b>HR</b>	Imajte na umu da se proizvod ne smije koristiti/pustiti u rad bez uputa za uporabu na lokalnom jeziku. Ako niste primili priručnik za uporabu na vašem lokalnom jeziku kada je proizvod isporučen, kontaktirajte nas. Poslat ćemo vam ih besplatno u zemlje EU / EFTA. Za zemlje izvan EU / EFTA, rado ćemo vam pružiti ponudu za priručnik za uporabu na lokalnom jeziku ako prijedlog ne može organizirati trgovac/uvoznik.
<b>LV</b>	Lūdzu, ņemiet vērā, ka izstrādājumu nedrīkst lietot/nodot ekspluatācijā bez lietošanas instrukcijas vietējā valodā. Ja līdz ar izstrādājuma piegādi neesat saņēmis lietošanas instrukciju valsts valodā, lūdzu, sazinieties ar mums. ES/EFTA valstīs mēs jums tās nosūtīsim bez maksas. Valstīs ārpus ES/EFTA valstīm, ja tulkojumu nevarēs nodrošināt tirgotājs/importētājs, mēs labprāt sniegsim jums ekspluatācijas instrukciju vietējā valodā.
<b>LT</b>	Atkreipkite dėmesį, kad gaminio negalima naudoti ir (arba) pradėti eksploatuoti be naudojimo instrukcijos vietine kalba. Jei kartu su gaminiu pristatymu negavote naudojimo instrukcijos savo šalies kalba, susisiekite su mumis. ES / ELPA šalyse jas išsiųsime nemokamai. ES / ELPA nepriklausančiose šalyse mes mielai pateiksime jums eksploataavimo instrukcijų vietine kalba pasiūlymą, jei pardavėjas / importuotojas negalės išversti instrukcijų į vietinę kalbą.
<b>NO</b>	Vær oppmerksom på at produktet ikke må brukes/tas i bruk uten en bruksanvisning på det lokale språket. Hvis du ikke har mottatt en bruksanvisning på ditt eget språk ved levering av produktet, ber vi deg ta kontakt med oss. Vi sender deg bruksanvisningen kostnadsfritt i EU/EFTA-land. For land utenfor EU/EFTA gir vi deg gjerne et tilbud på en bruksanvisning på det lokale språket hvis oversettelsen ikke kan ordnes av forhandleren/importøren.
<b>PT</b>	Tenha em atenção que o produto não pode ser utilizado/colocado em funcionamento sem um manual de instruções na língua local. Se não tiver recebido o manual de instruções na sua língua nacional com a entrega do produto, contacte-nos. O envio é gratuito nos países da UE / EFTA. Para os países fora da UE / EFTA, teremos todo o gosto em fornecer-lhe um orçamento para o manual de instruções na língua local, se a tradução não puder ser organizada pelo revendedor / importador.
<b>RO</b>	Vă rugăm să rețineți că produsul nu poate fi utilizat / pus în funcțiune fără instrucțiuni de utilizare în limba locală. Dacă nu ați primit instrucțiuni de utilizare în limba dvs. națională odată cu livrarea produsului, vă rugăm să ne contactați. Vi le vom trimite gratuit în țările UE / AELS. Pentru țările din afara UE / AELS, vom fi bucuroși să vă furnizăm o ofertă pentru instrucțiuni de utilizare în limba locală, dacă traducerea nu poate fi organizată de către dealer / importator.
<b>SE</b>	Observera att produkten inte får användas / tas i drift utan bruksanvisning på det lokala språket. Om du inte har fått en bruksanvisning på ditt språk i samband med leveransen av produkten, vänligen kontakta oss. Vi skickar dem kostnadsfritt till dig i EU / EFTA-länder. För länder utanför EU / EFTA ger vi dig gärna en offert på bruksanvisningar på det lokala språket om översättningen inte kan organiseras av återförsäljaren / importören.
<b>SK</b>	Upozorňujeme, že výrobok sa nesmie používať/uvádzať do prevádzky bez návodu na obsluhu v miestnom jazyku. Ak ste spolu s výrobkom nedostali návod na obsluhu vo vašom národnom jazyku, kontaktujte nás. V krajinách EÚ/EZVO vám ich zašleme bezplatne. V krajinách mimo EÚ/EZVO vám radi poskytneme cenovú ponuku na návod na obsluhu v miestnom jazyku, ak preklad nemôže zabezpečiť predajca/dovozca.
<b>SL</b>	Upoštevajte, da izdelka ne smete uporabljati brez navodil za uporabo v lokalnem jeziku. Če z dostavo izdelka niste prejeli navodil za uporabo v nacionalnem jeziku, se obrnite na nas. V državah EU/EFTA vam jih bomo poslali brezplačno. Za države zunaj EU/EFTA vam bomo z veseljem pripravili ponudbo za navodila za uporabo v lokalnem jeziku, če prevoda ne more zagotoviti prodajalec/uvoznik.
<b>CZ</b>	Upozorňujeme, že výrobek nesmí být používán / uveden do provozu bez návodu k obsluze v místním jazyce. Pokud jste spolu s výrobkem neobdrželi návod k obsluze ve svém národním jazyce, kontaktujte nás. V zemích EU/EFTA vám je zašleme zdarma. V zemích mimo EU/EFTA vám rádi poskytneme nabídku návodu k obsluze v místním jazyce, pokud překlad nemůže zajistit prodejce/dovozce.
<b>HU</b>	Felhívjuk figyelmét, hogy a termék nem használható/helyezhető üzembe a helyi nyelven kiadott használati utasítás nélkül. Ha a termék szállításával együtt nem kapta meg a nemzeti nyelven készült használati utasítást, kérjük, lépjen kapcsolatba velünk. Az EU/EFTA-országokban ingyenesen elküldjük Önnek. Az EU / EFTA-n kívüli országok esetében szívesen adunk Önnek árajánlatot a helyi nyelvű kezelési útmutatóra, ha a fordítást a kereskedő / importőr nem tudja megszervezni.